



Connect Tech Inc.
Embedded Computing Experts

USERS GUIDE



Astro Carrier for NVIDIA® Jetson™ TX2/TX2i

CTIM-00456 Revision 0.24 2021-10-04



CONNECT TECH
www.connecttech.com
support@connecttech.com

TABLE OF CONTENTS

Table of Contents	2
Preface	4
Disclaimer	4
Customer Support Overview	4
Contact Information	4
Limited Product Warranty	5
Copyright Notice	5
Trademark Acknowledgment	5
ESD Warning	6
Revision History	6
Introduction	8
Product Features and Specifications	8
Part Numbers / Ordering Information	9
Product Overview	10
Block Diagram	10
Connector Locations	11
Connector Summary	12
DIP Switch Summary	12
Detailed Feature Description	13
Jetson™ TX2 or TX2i Board-to-Board Connector	13
Jetson™ TX2 or TX2i Compatibility	14
Auto-Power Mode	15
microSD Card Slot	15
NVIDIA Jetson TX2 or TX2i Fan	16
Mini-PCIe and mSATA Modules	17
Half and Full Length Mini-PCIe Module Installation	17
Mini-PCIe	18
mSATA	20
Connect Tech High Density Connector	22
HD AUDIO – HDC	25
CAN Bus – HDC	25
USB 2.0 – HDC	26
Force USB Recovery Mode	26
USB 3.0 – HDC	27
System/I2C/GPIO – HDC	27
HDMI – HDC	28
Serial – HDC	29
Serial Configuration	29
Locked/Hardwired Configuration	29
Dual RS-232	29
Serial 0 RS-232/Serial 1 RS-485	29
Dual RS-485	30
Dual Disable	30

10/100/1000 Ethernet (GBE) – HDC.....	30
Camera Serial Interface (CSI-2) – HDC.....	31
Power Input – HDC.....	31
+3.3V Power Output – HDC.....	31
+1.8V Power Output – HDC.....	32
Typical Installation	32
Power Supply	33
On-Board Indicator LEDs	33
CURRENT CONSUMPTION DETAILS.....	34
Software / BSP Details	34
Connect Tech’s Custom L4T BSP (CTI-L4T)	34
NVIDIA Linux For Tegra (L4T).....	35
NVIDIA Jetpack for L4T	35
Thermal Details	35
Mechanical Drawings	37
3D Model Download.....	37
Weight.....	37
Astro Carrier Outline and Dimensions.....	37
Astro System Stacking Height.....	38
CTI Breakout Boards.....	39
Available Breakout Boards	39
Breakout Board XBG201, XBG206 Technical Details	40
XBG201 Connector Locations	40
Stereo Output Header	40
RTC Battery Header	41
Input Power Connector	41
System Control Header.....	42
Force Recovery	42
GPIO Header	43
I2C Header	43
Serial (RS-232/485) Header	44
MIPI Camera Connector	45
Astro Breakout Board XBG201 Outline and Dimensions	46
Custom Breakout Board	46
Reference Design Package – OEM Astro Breakout Board	46
Cables	47
Available Cables.....	47

PREFACE

Disclaimer

The information contained within this user's guide, including but not limited to any product specification, is subject to change without notice.

Connect Tech assumes no liability for any damages incurred directly or indirectly from any technical or typographical errors or omissions contained herein or for discrepancies between the product and the user's guide.

Customer Support Overview

If you experience difficulties after reading the manual and/or using the product, contact the Connect Tech reseller from which you purchased the product. In most cases the reseller can help you with product installation and difficulties.

In the event that the reseller is unable to resolve your problem, our highly qualified support staff can assist you. Our support section is available 24 hours a day, 7 days a week on our website at: <https://connecttech.com/support/resource-center>. See the contact information section below for more information on how to contact us directly. Our technical support is always free.

Contact Information

Contact Information	
Mail/Courier	Connect Tech Inc. Technical Support 489 Clair Rd. W. Guelph, Ontario Canada N1L 0H7
Contact Information	sales@connecttech.com support@connecttech.com www.connecttech.com Toll Free: 800-426-8979 (North America only) Telephone: +1-519-836-1291 Facsimile: 519-836-4878 (on-line 24 hours)
Support	Please go to the Connect Tech Resource Center for product manuals, installation guides, device drivers, BSPs and technical tips. Submit your technical support questions to our support engineers. Technical Support representatives are available Monday through Friday, from 8:30 a.m. to 5:00 p.m. Eastern Standard Time.

Limited Product Warranty

Connect Tech Inc. provides a one-year Warranty for the Astro Carrier for Jetson™ TX2/TX2i. Should this product, in Connect Tech Inc.'s opinion, fail to be in good working order during the warranty period, Connect Tech Inc. will, at its option, repair or replace this product at no charge, provided that the product has not been subjected to abuse, misuse, accident, disaster or non-Connect Tech Inc. authorized modification or repair.

You may obtain warranty service by delivering this product to an authorized Connect Tech Inc. business partner or to Connect Tech Inc. along with proof of purchase. Product returned to Connect Tech Inc. must be pre-authorized by Connect Tech Inc. with an RMA (Return Material Authorization) number marked on the outside of the package and sent prepaid, insured and packaged for safe shipment. Connect Tech Inc. will return this product by prepaid ground shipment service.

The Connect Tech Inc. Limited Warranty is only valid over the serviceable life of the product. This is defined as the period during which all components are available. Should the product prove to be irreparable, Connect Tech Inc. reserves the right to substitute an equivalent product if available or to retract the Warranty if no replacement is available.

The above warranty is the only warranty authorized by Connect Tech Inc. Under no circumstances will Connect Tech Inc. be liable in any way for any damages, including any lost profits, lost savings or other incidental or consequential damages arising out of the use of, or inability to use, such product.

Copyright Notice

The information contained in this document is subject to change without notice. Connect Tech Inc. shall not be liable for errors contained herein or for incidental consequential damages in connection with the furnishing, performance, or use of this material. This document contains proprietary information that is protected by copyright. All rights are reserved. No part of this document may be photocopied, reproduced, or translated to another language without the prior written consent of Connect Tech, Inc.

Copyright © 2021 by Connect Tech, Inc.

Trademark Acknowledgment

Connect Tech, Inc. acknowledges all trademarks, registered trademarks and/or copyrights referred to in this document as the property of their respective owners. Not listing all possible trademarks or copyright acknowledgments does not constitute a lack of acknowledgment to the rightful owners of the trademarks and copyrights mentioned in this document.

ESD Warning



Electronic components and circuits are sensitive to ElectroStatic Discharge (ESD). When handling any circuit board assemblies including Connect Tech COM Express carrier assemblies, it is recommended that ESD safety precautions be observed. ESD safe best practices include, but are not limited to:

- Leaving circuit boards in their antistatic packaging until they are ready to be installed.
- Using a grounded wrist strap when handling circuit boards, at a minimum you should touch a grounded metal object to dissipate any static charge that may be present on you.
- Only handling circuit boards in ESD safe areas, which may include ESD floor and table mats, wrist strap stations and ESD safe lab coats.
- Avoiding handling circuit boards in carpeted areas.
- Try to handle the board by the edges, avoiding contact with components.

REVISION HISTORY

Revision	Date	Changes
0.00	2016/02/25	Initial Release
0.01	2016/03/11	Updated images
0.02	2016/06/08	Added additional product information
0.03	2016/06/10	Corrected assembly drawings
0.04	2016/06/14	Added fan, software, and thermal sections
0.05	2016/07/07	Fixed formatting on thermal section
0.06	2016/08/10	Fixed BSP Download Link
0.07	2016/10/14	Added note on video input
0.08	2016/11/16	Updated assembly drawings and cable information
0.09	2016/11/24	Added note on power supply, MSG062
0.10	2016/12/01	Added link to breakout board reference design package
0.11	2017/04/18	Updated MSG062 Cable Drawing
0.12	2017/04/27	Updated feature set, added TX2 specs

0.13	2017/05/11	Updated mating connector PN for break out power connector
0.14	2017/05/29	Updated power supplies
0.15	2017/06/30	RTC Battery, Corrected Pinout Label
0.16	2017/08/04	Added cable drawing links, removed drawings from doc
0.17	2017/09/08	Added TX1/2 Support Switch Settings
0.18	2018/03/08	Added GPIO KDB link
0.19	2018/03/29	Corrected XBG201 serial pinout
0.20	2018/07/27	Added GMSL video inputs (ASG012), Updated table format, Added TX2i and XBG206.
0.21	2018/10/01	Added CAN bus to HDC, updated S1 function
0.22	2019-04-17	Added TX2i Power Circuitry Note; HDMI 2.0 support
0.23	2020-07-08	Corrected serial ports for UART0 and UART1
0.24	2021-10-04	Updated format, Updated address, Removed TX1

INTRODUCTION

Astro is specifically designed to work with the NVIDIA® Jetson™ TX2/TX2i supercomputer-on-module. The Astro Carrier provides access to features found on the Jetson™ TX2 or TX2i module in an extremely small footprint (87mm x 57mm / 3.43" x 2.24").

The Astro Carrier for Jetson™ TX2/TX2i provides a high-density board to board connector for use with either off-the-shelf or custom breakout boards, dramatically reducing the need for cabling.

With all of the complex circuitry already on the Astro carrier, such as Gigabit Ethernet, USB 3.0, Serial, and Display, the design of a unique breakout board can be done with minimal effort using Connect Tech's design services or by the user. Connect Tech already offers the XBG201 breakout board, as well as a single board carrier solution called the Astro Carrier for Jetson™ TX2/TX2i. For more information on these two products please contact sales@connecttech.com.

The Astro Carrier provides expansion via Mini PCI Express and mSATA, in addition to a micro-SD Card slot.

Product Features and Specifications

Specifications	
PCB Size / Overall Size	87mm x 57mm (3.43" x 2.24") 3D STEP Model: download here
Display	1x HDMI Interface (Supports up to HDMI 2.0 UHD 4K [2160p] at 60Hz)
Ethernet	2x Gigabit Ethernet (10/100/1000) Links
USB	1x USB 3.0 Links 2x USB 2.0 Links
SATA	1x SATA Link
Audio	HD Audio Link: 1x Output
Serial	2x RS-232/RS-485 Links
Mini-PCIe/mSATA	1x Mini-PCIe Half or Full Sized (Use of Full Size Removes mSATA Slot) 1x mSATA Half Size
SD Card	1x microSD Card Slot
GPIO	4x GPIO
CAN BUS	1x CAN bus
Video Input	1x MIPI CSI-2 (2-lane) 2x GMSL* <ul style="list-style-type: none"> Note: GMSL video inputs only supported on PN: ASG012 with RidgeRun Drivers/Software Support. GMSL Software Info Link: https://developer.ridgerun.com/wiki/index.php?title=MAX96705_MAX9286_GMSL_SERDES_Linux_Drivers. Contact: support@ridgerun.com

	Power-Over-Coax Not Supported, external power must be provided to GMSL Camera Module
Misc.	1x I2C Link 1x System Control (PWR and RST buttons, etc.) 1x RTC Battery Input
Power Requirements	+7.5V to +14.0V DC Input Range +12V DC Nominal Input The above values represent the Astro Carrier only. Breakout board power input requirements will not match the above. Please see the CTI Breakout Boards section of this document for specific breakout board power requirements.
Operating Temperature	-40°C to +85°C
Weight	46 grams (with stand-offs attached)
Accessories	Breakout Boards Cable Kit
Warranty and Support	1 Year Warranty and Lifetime Free Support

Part Numbers / Ordering Information

Part Number	
ASG001	Astro Carrier for NVIDIA® Jetson™ TX2/TX2i
ASG012	Astro Carrier for NVIDIA® Jetson™ TX2/TX2i with GMSL
XBG201	Astro Carrier Breakout Board for NVIDIA® Jetson™ TX2
XBG206	Astro Carrier Breakout Board for NVIDIA® Jetson™ TX2i

PRODUCT OVERVIEW

Block Diagram

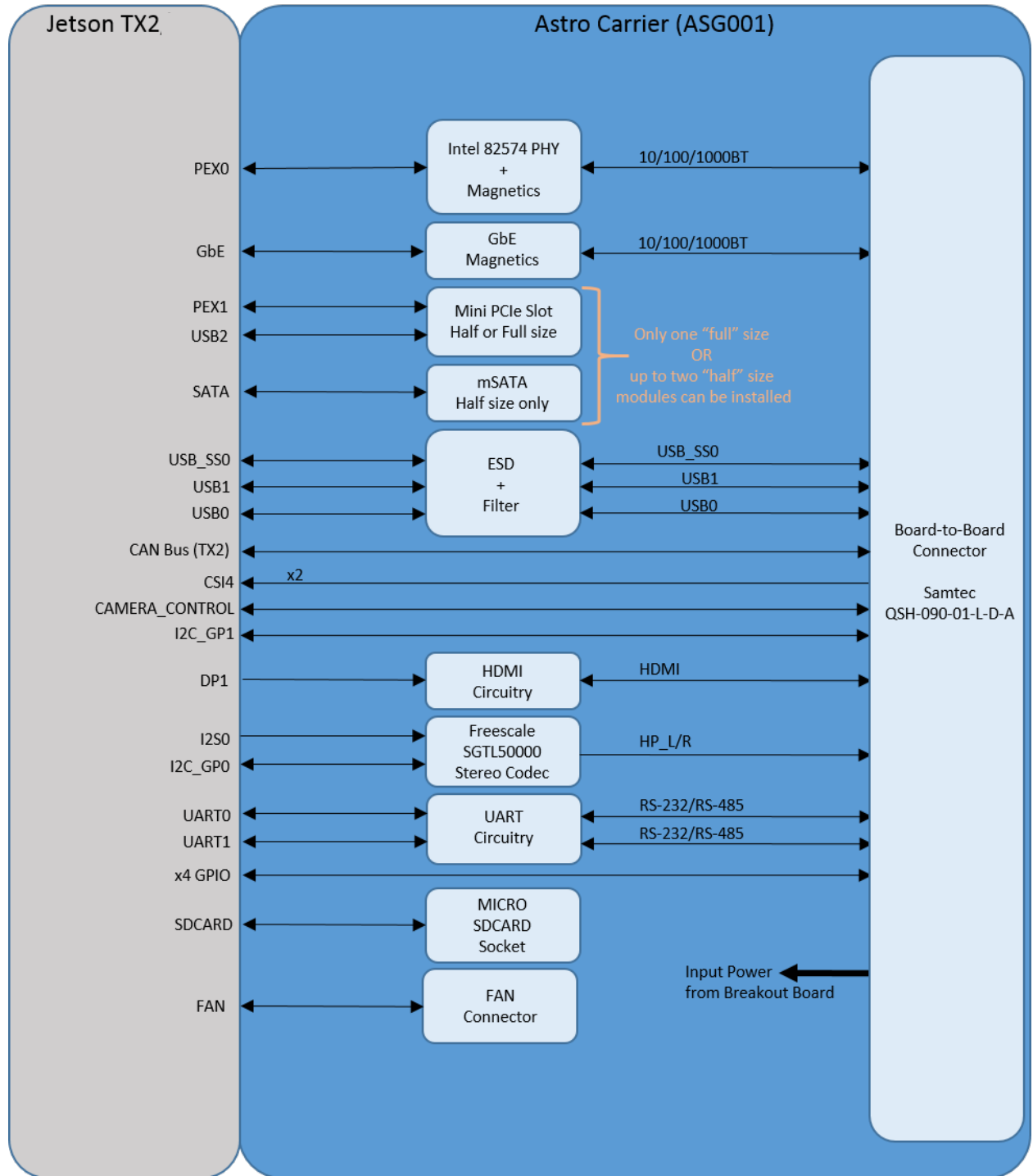

Connector Locations

TOP SIDE

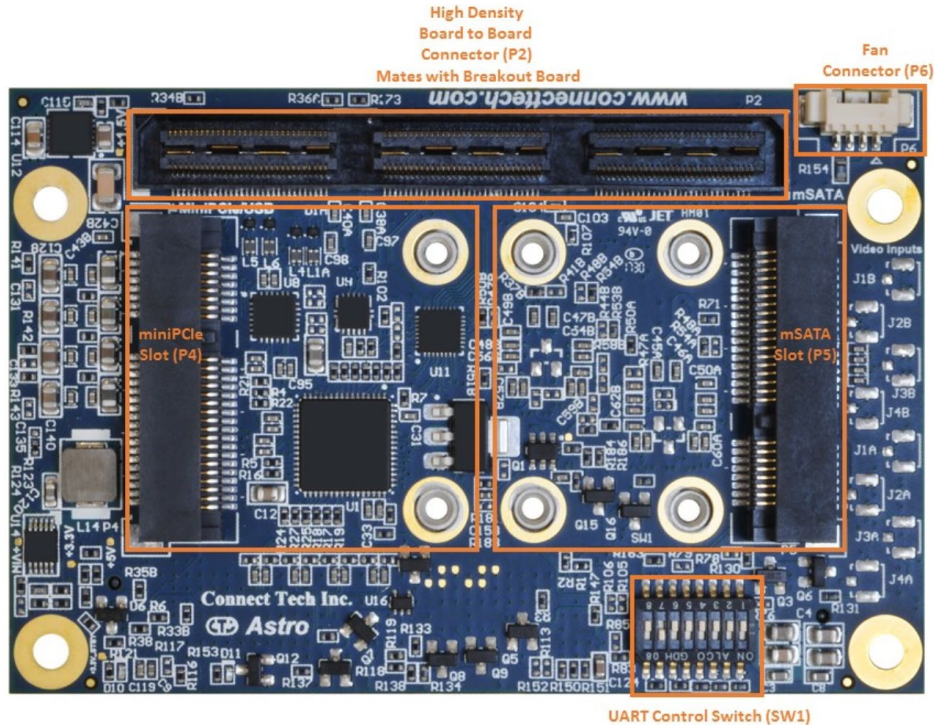

SECONDARY SIDE

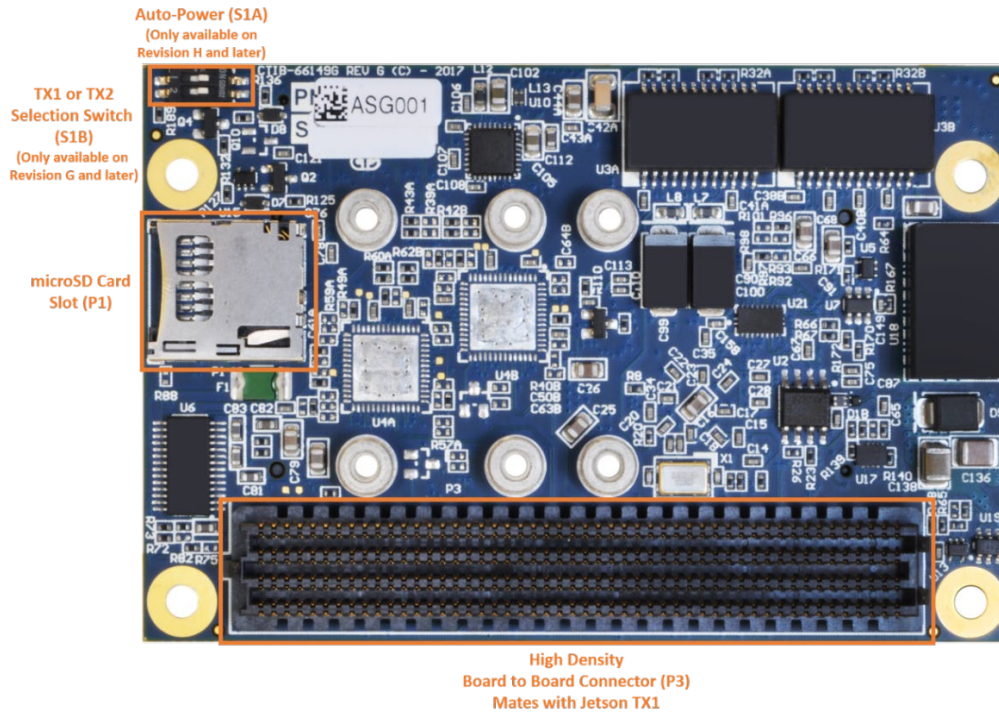

Connector Summary

Designator	Connector	Description
P1	microSD Card Socket	microSD Card Socket
P2	High Density Board to Board Connector	Connect Tech High Density Board to Board Connector that mates with the Breakout Board
P3	High Density Board to Board Connector	High Density Board to Board Connector that mates with the Jetson™ TX2 or TX2i
P4	Mini-PCIe Slot	Mini-PCIe Half or Full Sized Card Slot
P5	mSATA Slot	mSATA Half Sized Card Slot
P6	Fan Connector	+5V Fan Connector

DIP Switch Summary

Designator	Function	Description
SW1A	Serial Selection	DIP Switches for Controlling Serial Format and Related Features
SW1B	Serial Selection	DIP Switches for Controlling Serial Format and Related Features
SW1C	Serial Selection	DIP Switches for Controlling Serial Format and Related Features
SW1D	Serial Selection	DIP Switches for Controlling Serial Format and Related Features
SW1E	Serial Selection	DIP Switches for Controlling Serial Format and Related Features
SW1F	Serial Selection	DIP Switches for Controlling Serial Format and Related Features
SW1G	OTG_ID	Enables/Disables USB Host operation of USB2 port 0
SW1H	RTC Voltage	Allows for shorting the RTC voltage to Ground
S1A	Auto-Power	Enable/Disable auto boot when power is applied
S1B	TX2 or TX2i Selection	Set this switch to match whatever module you are using: Jetson™ TX2 or TX2i to ensure full compatibility

DETAILED FEATURE DESCRIPTION

Jetson™ TX2 or TX2i Board-to-Board Connector

The processor and chipset are implemented on the Jetson™ TX2 or TX2i Module, which connects to the Astro Carrier Board via a Samtec SEARAY™ stacking connector.

Function	Board-to-Board Mating Connector with Jetson™ TX2/TX2i	
Location	P3	
Type	Samtec “SEARAY™” Connector	
Carrier Connector P/N	SEAM-50-03.5-S-08-2-A-K-TR (8.5mm stacking height) Manufacturer: Samtec	
Mating Connector P/N	SEAF-50-05-S-08-02-A-K (installed on Jetson™ TX2/TX2i) Manufacturer: Samtec	
Pinout	Refer to NVIDIA’s Jetson™ TX2 or TX2i System-on-Module datasheets for pinout details.	

Jetson™ TX2 or TX2i Compatibility

Due to pin-muxing within the Jetson™ TX2 and TX2i modules, the Astro Carrier features a DIP switch that will ensure full compatibility depending on which Jetson™ module you use. This DIP switch is only present on-board revisions G and later. Astro Carrier board revisions F and earlier do not offer full Jetson™ TX2 or TX2i compatibility.

To determine which revision of the Astro Carrier you have please see the revision label as per the image below.

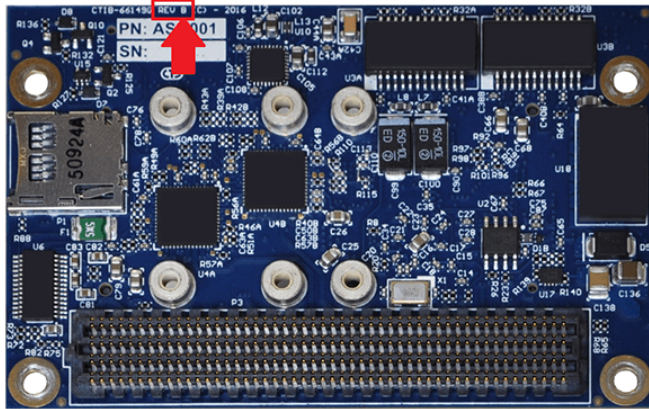

Function	Jetson™ TX2 or TX2i Select Switch
Location	S1B
Type	DIP Switch
Description	If you are using a Jetson™ TX2 or TX2i then leave S1B in the ON position to ensure full compatibility. S1B ON = Full Jetson™ TX2/TX2i Support



For further information please see the following notice regarding Astro Carrier compatibility:
<http://connecttech.com/resource-center/kdb344-cti-nvidia-jetson-carrier-board-tx2-tx1-compatibility/>

Auto-Power Mode

The Astro carrier features an Auto-Power circuit. If the switch is in the ON position the Jetson™ TX2/TX2i will boot when power is applied to the carrier. If the switch is in the OFF position a power button input signal is required to boot the Jetson™ TX2/TX2i module.

Function	Auto-Power Select Switch	
Location	S1A	
Type	DIP Switch	
Description	S1A OFF = Auto-Power Disabled S1A ON = Auto-Power Enabled	

Note: Due to the changes done to the PMIC circuitry of the TX2i Jetson Module the Astro Carrier will always remain ON when in AT (Automatic Power ON) and ATX (Push Power button) modes. This will cause the Astro Carrier to automatically power ON when voltage is applied to the system. The system will in addition be unable to shut down in software (Soft Shutdown), due to the characteristics of the TX2i power circuitry as such the system will perform a Reset/Reboot function.

microSD Card Slot

The Astro Carrier features a microSD Card Slot for system purposes. It is connected directly to the SDCARD interface on the Jetson™ TX2 or TX2i.

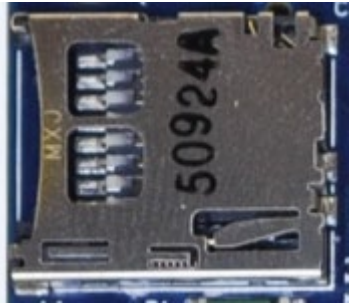
Function	microSD Card Slot		
Location	P1		
Type	Molex microSD Memory Card Connector		
P/N	5025700893		
Pinout	Pin	Description	
	1	SD_D2	
	2	SD_D3	
	3	SD_CMD	
	4	SD_VDD	
	5	SD_CLK	
	6	GND	
	7	SD_D0	
	8	SD_D1	
	9	GND	
10	SD_CD#		

NVIDIA Jetson TX2 or TX2i Fan

Function	NVIDIA Jetson TX2 or TX2i Fan Control	
Location	P6	
Type	Molex PicoBlade Header	
P/N	53261-0471	
Mating	51021-0400	
Pinout	Pin	Description
	1	GND
	2	+5V
	3	TACH
	4	PWM

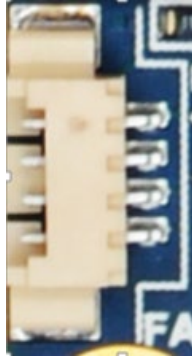

NOTE: Please note that FAN PWM (speed control) is NOT natively supported by the stock L4T builds. To enable PWM functionality (speed control) users must deploy CTI-L4T BSP. Please see the software section of this document for more details.

Mini-PCIe and mSATA Modules

Half and Full Length Mini-PCIe Module Installation

The Astro Carrier is designed to allow for two half sized mini modules, one mini PCIe and mSATA module, or one full size mini PCIe module. To install a half-length module simply shift the spacers to the appropriate location. The M2.5 spacers and screws required to mount the mini modules ship in the same box as the Astro Carrier. Please see the images below showing the full assembly of both options: two half-sized modules or one full-size module.

Mini PCIe Full Size Installation:

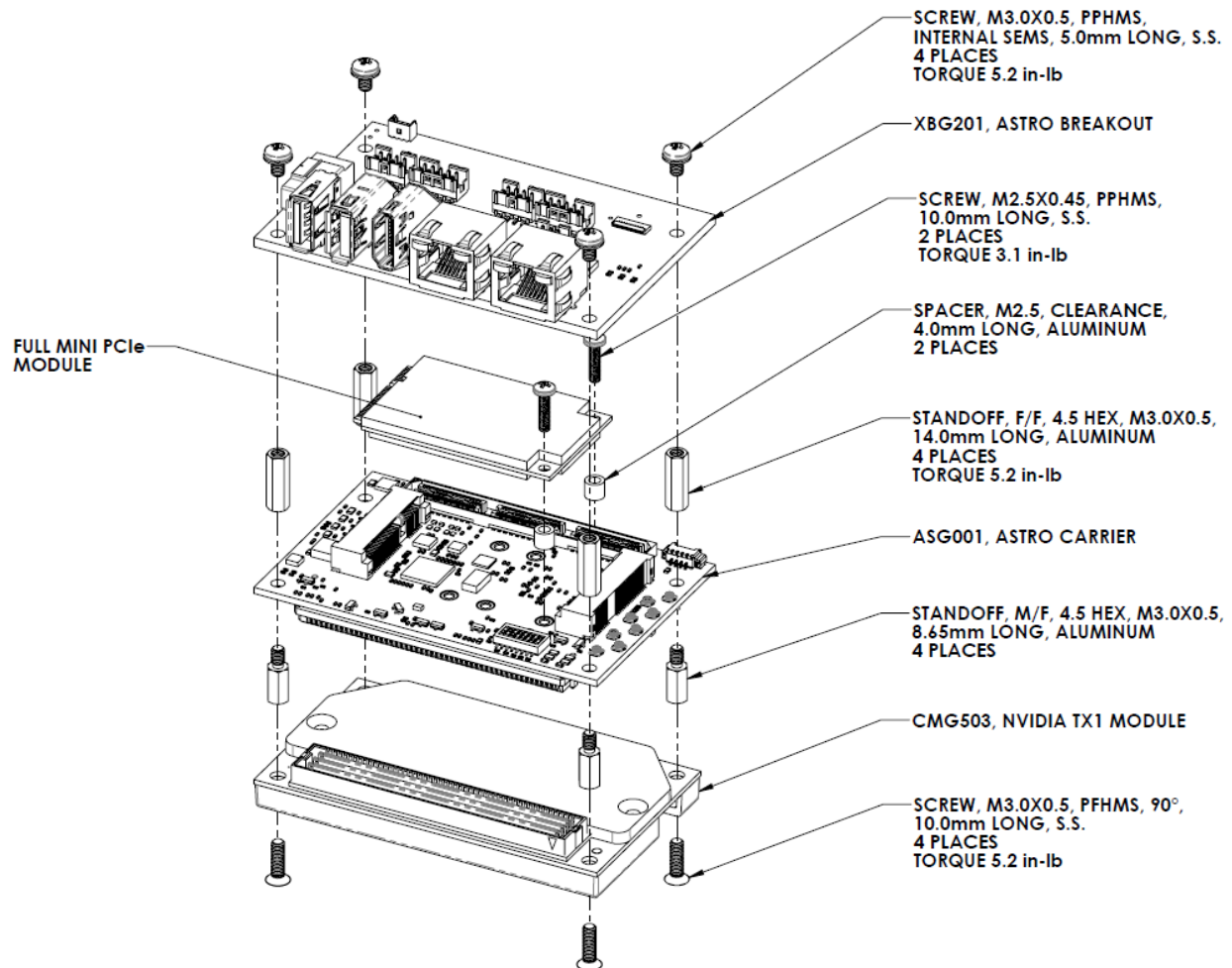

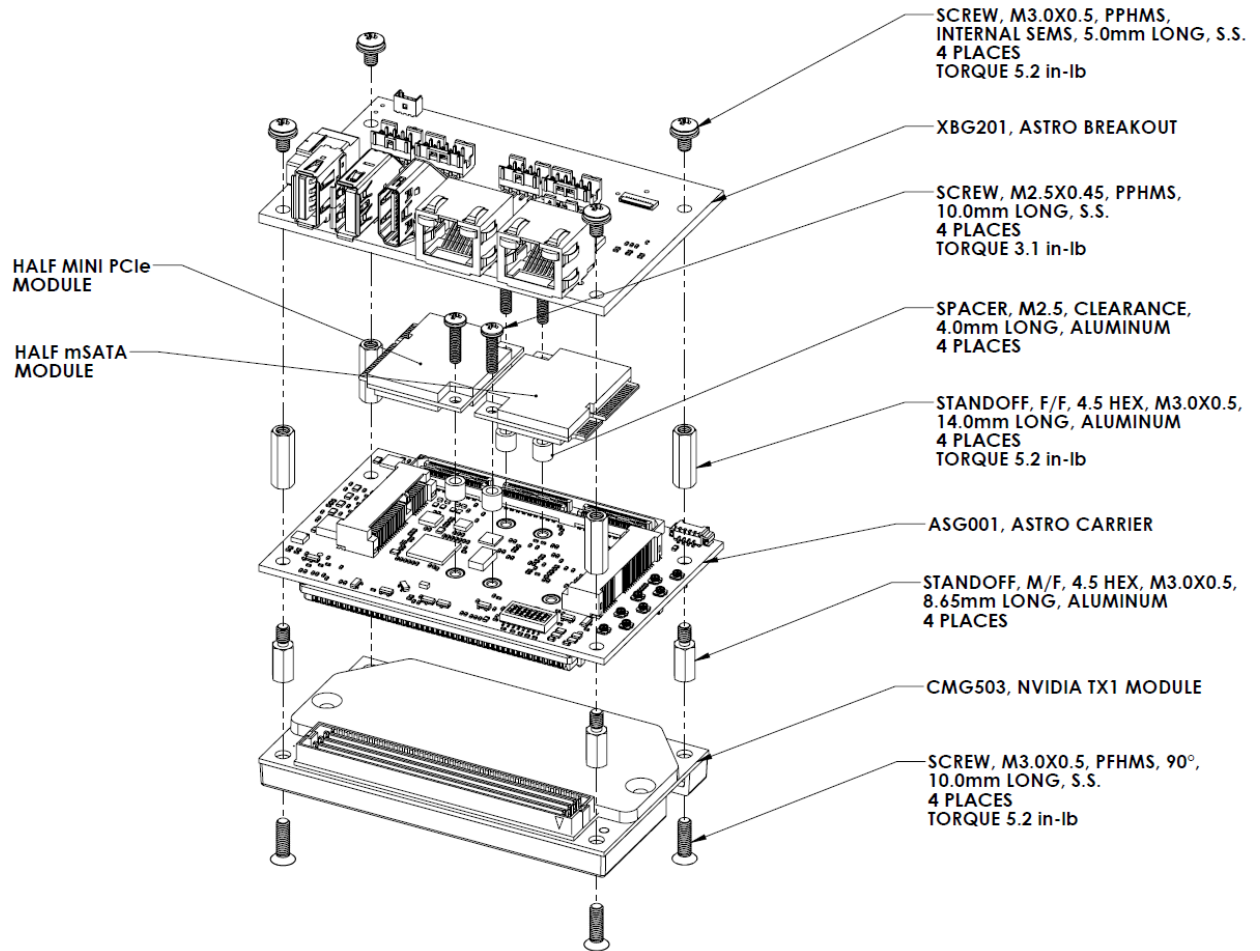
Half Size Installation:

Mini-PCle

Function	Mini-PCle Slot	
Location	P4	
Type	Molex Card Edge connector	
P/N	48338-0065	
Pinout	Pin	Mini-PCle Description
	1	-
	2	+3.3V
	3	-
	4	GND
	5	-
	6	+1.5V
	7	CLKREQ#

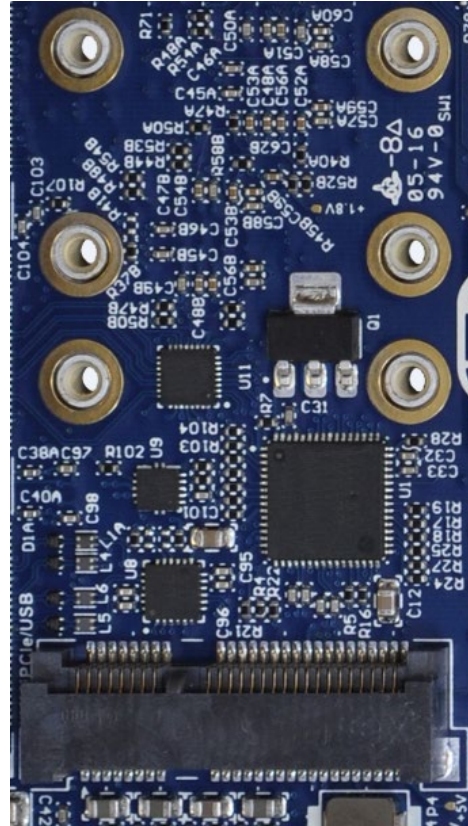

8	-
9	GND
10	-
11	PCIe CLK+
12	-
13	PCIe CLK-
14	-
15	GND
16	-
17	-
18	GND
19	-
20	W_DISABLE#
21	RESV
22	-
23	PCIe RX+
24	+3.3V
25	PCIe RX-
26	GND
27	GND
28	+1.5V
29	GND
30	-
31	PCIe TX-
32	-
33	PCIe TX+
34	GND
35	GND
36	USB D-
37	GND
38	USB D+
39	+3.3V
40	GND
41	+3.3V
42	-



43	RESV
44	-
45	-
46	-
47	-
48	+1.5V
49	-
50	GND
51	-
52	+3.3V

mSATA

Function	mSATA Slot	
Location	P5	
Type	Molex Card Edge connector	
P/N	48338-0065	
Pinout	Pin	mSATA Description
	1	-
	2	+3.3V
	3	-
	4	GND
	5	-
	6	+1.5V
	7	-
	8	-
	9	GND
	10	-
	11	-
	12	-
	13	-
	14	-
	15	GND
	16	-
	17	-

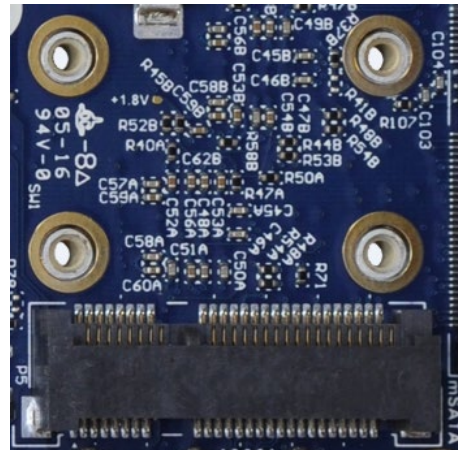

18	GND
19	-
20	-
21	RESV
22	RESET#
23	SATA TX+
24	+3.3V
25	SATA TX-
26	GND
27	GND
28	+1.5V
29	GND
30	-
31	SATA RX-
32	-
33	SATA RX+
34	GND
35	GND
36	-
37	GND
38	-
39	+3.3V
40	GND
41	+3.3V
42	-
43	RESV
44	-
45	-
46	-
47	-
48	+1.5V
49	-
50	GND
51	-
52	+3.3V

Connect Tech High Density Connector

The Astro Carrier main advantage is the High Density Connector (HDC) allowing for easy custom breakout boards.

Function	Connect Tech High Density Connector			
Location	P2			
Type	Samtec Qstrip High Speed Ground Plane Socket			
Carrier P/N	QSH-090-01-L-D-A			
Mating P/N	QTH-090-XX-L-D-A (On Breakout Board)			
Pinout Bank 1	Description	Pin	Pin	Description
	GND	1	2	RTC_BAT
	BATLOW#	3	4	RTC_BAT
	RESET_IN#	5	6	GND
	PWR_BUTTON#	7	8	GBE1_LINK1000#
	SLEEP#	9	10	GBE1_LINK100#
	RESET_OUT#	11	12	GBE1_LINK#
	GND	13	14	GBE1_ACT#
	-	15	16	-
	-	17	18	GBE1_MDI_3_P
	GND	19	20	GBE1_MDI_3_N
	USB2_1_VBUS	21	22	GBE1_MDI_2_N
	GND	23	24	GBE1_MDI_2_P
	USB3_0_SS_TX_N	25	26	GBE1_MDI_1_N
	USB3_0_SS_TX_P	27	28	GBE1_MDI_1_P
	GND	29	30	GBE1_MDI_0_N
	USB3_0_SS_RX_N	31	32	GBE1_MDI_0_P
	USB3_0_SS_RX_P	33	34	-
	GND	35	36	GBE1_GND
	USB2_1_DATA_N	37	38	GBE0_GND
	USB2_1_DATA_P	39	40	-
	-	41	42	GBE0_MDI_3_N
	GND	43	44	GBE0_MDI_3_P
	USB2_0_DATA_N	45	46	GBE0_MDI_2_N
	USB2_0_DATA_P	47	48	GBE0_MDI_2_P



GND	49	50	GBEO_MDI_1_N
USB2_VBUS_A	51	52	GBEO_MDI_1_P
GND	53	54	GBEO_MDI_0_P
FORCE_REC#	55	56	GBEO_MDI_0_N
NC	57	58	-
GND	59	60	GBEO_LINK100#
+3.3V	BLADE A	+3.3V	

Pinout	Description	Pin	Pin	Description
Bank 2	HDMI_UTLY	61	62	GBEO_LINK100#
	HDMI_HPD	63	64	GBEO_LINK#
	HDMI_CEC	65	66	GBEO_ACT#
	GND	67	68	GND
	DDI_DAT	69	70	-
	DDI_CLK	71	72	-
	GND	73	74	GND
	TMDS_LANE2_P	75	76	-
	TMDS_LANE2_N	77	78	-
	GND	79	80	GND
	TMDS_LANE1_P	81	82	CAN1_TX
	TMDS_LANE1_N	83	84	GND
	GND	85	86	CAN_WAKE
	TMDS_LANE0_P	87	88	CAN1_ERR
	TMDS_LANE0_N	89	90	GND
	GND	91	92	CAN0_TX
	TMDS_CLK_P	93	94	CAN1_STBY
	TMDS_CLK_N	95	96	GND
	GND	97	98	CAN0_RX
	-	99	100	CAN0_ERR
HDMI_5V_PWR	101	102	GND	
HDMI_5V_PWR	103	104	CAN1_RX	
HDMI_5V_PWR	105	106	CAN0_STBY	
GND	107	108	GND	

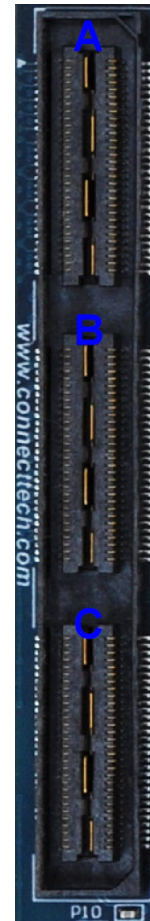

-	109	110	+1.8V
-	111	112	+1.8V
GND	113	114	GND
-	115	116	HD_AUDIO_HP_R
-	117	118	HD_AUDIO_HP_L
GND	119	120	GND
GND	BLADE B	GND	

Pinout Bank 3	Description	Pin	Pin	Description
	GND	121	122	GPIO_EXP1_INT
	UART1_RX_N	123	124	GPIO_EXPO_INT
	UART1_RX_P	125	126	GPIO9
	GND	127	128	GPIO8
	UART1_TX_N	129	120	-
	UART1_TX_P	131	132	GND
	GND	133	134	CSI4_D1_N
	UART0_RX_N	135	136	CSI4_D1_P
	UART0_RX_P	137	138	GND
	GND	139	140	CSI4_D0_N
	UART0_TX_N	141	142	CSI4_D0_P
	UART0_TX_P	143	144	GND
	GND	145	146	CSI4_CLK_N
	GND	147	148	CSI4_CLK_P
	I2C_GP1_SDA (+3.3V)	149	150	GND
	I2C_GP1_SCL (+3.3V)	151	152	-
	GND	153	154	-
	CAMERA1_RST	155	156	GND
	CAMERA1_PWR	157	158	-
	CAMERA1_MCLK	159	160	-
	GND	161	162	GND
	GND	163	164	-
	CAMERA_VSYNC	165	166	-



CAMERA_FLSH_EN	167	168	GND
CAMERA_STROBE	169	170	-
GND	171	172	-
GND	173	174	GND
CAMERA0_RST	175	176	-
CAMERA0_PWR	177	178	-
CAMERA0_MCLK	179	180	GND
+VIN	BLADE_C	+VIN	

HD AUDIO – HDC

The Astro Carrier features HD Audio capabilities with the assistance of the NXP (Freescale) SGTL5000 Audio codec. From the Codec, 1 Headphone Output is available on the HDC.

Function	HD Audio
Location	P2
HDC Bank	B
Pins	116, 118
Design Instruction	No additional circuitry required Route direct to header/connector/device

CAN Bus – HDC

The Astro Carrier features a CAN interface routed directly from the TX2/TX2i to the HDC.

Function	CAN Bus
Location	P2
HDC Bank	B
Pins	82, 86, 88, 92, 94, 98, 100, 104, 106
Design Instruction	Route to CAN transceiver

USB 2.0 – HDC

The Astro Carrier has two USB 2.0 Ports and one USB 3.0 Port available at the HDC.

Function	USB 2.0
Location	P2
HDC Bank	A
Pins	21, 37, 39, 45, 47, 51 USB2 Port 0 – pins 45/47 USB2 Port 0 OTG_ID – pin 57 USB2 Port 0 VBUS – pin 51 USB2 Port 1 – pins 37/39
Design Instruction	Please note that the USB2_VBUS (Pins 21 and 51) supply +5V @ 0.9A No additional circuitry required USB magnetics (ESD/EMI) placed on Astro Carrier Route direct to header/connector/device

Force USB Recovery Mode

USB2 port 0 on pins 45 and 47 of the HDC can be used in force recovery mode. To enable force USB recovery mode using the Astro Carrier follow the steps below:

- 1) Power down the system completely. The system power MUST be OFF, not in suspend or sleep mode.
- 2) On the Astro Carrier change the DIP switch setting of SW1 so all switches are in the off position.



- 3) Connect USB2 port 0 to a host PC.
- 4) Power on the system.
- 5) With the system powered on, ensure to assert FORCE_RECOV#; while FORCE_RECOV# is low, trigger a reset by forcing RESET_OUT# low, release the RESET_OUT# and two seconds later release FORCE_RECOV#.

After successfully updating the system software, ensure to enable USB2 port 0 host operation by changing the DIP switch settings back to default, where switch 7 (OTG_ID) is in the ON position:



Switch 7 of SW1 MUST be in the ON position in order for USB2 port 0 to work as a host port as shown above.

USB 3.0 – HDC

Function	USB 3.0
Location	P2
HDC Bank	A
Pins	25, 27, 31, 33
Design Instruction	No additional circuitry required USB magnetics (ESDS/EMI) placed on Astro Carrier Route direct to header/connector/device

System/I2C/GPIO – HDC

The System pins include a power button, two reset signals, sleep input, battery low input, optional RTC battery input, and a force recovery input signal for the Jetson™ TX2 or TX2i module.

Function	System/I2C/GPIO	
Location	P2	
HDC Bank	A	
P/N	53261-0471	
Mating	51021-0400	
Pins	Signal Name	HDC Pin
	BATLOW#	3
	RTC_BAT	2 and 4
	RESET_IN#	5
	PWRBTN#	7
	SLEEP#	9
	RESET_OUT#	11
	GPIO8	128
GPIO9	126	

	GPIO_EXPO_INT	124
	GPIO_EXP1_INT	122
	I2C_GP1_SCL	151
	I2C_GP1_SDA	149
	FORCE_RECOV#	55
Design Instruction	<p>For the power button, resets, force recovery, sleep, and battery low signals: these are pulled up on the Jetson™ TX2 or TX2i module. A falling edge on these signals will trigger an event.</p> <p>The I2C interface is +3.3V and uses I2C bus 1 within Linux for Tegra.</p> <p>The four GPIO signals use +1.8V logic levels. The Astro Carrier routes GPIO signals to the HDC; please reference our GPIO KDB for TX2/TX2i values.</p> <p>Refer to the Jetson™ TX2 or TX2i module datasheet for nominal RTC battery voltage and supply requirements.</p> <p>For all signals listed above: No additional circuitry required Route direct to header/connector/device</p>	

HDMI – HDC

The Astro Carrier features one display output interface using HDMI 2.0.

Function	HDMI
Location	P2
HDC Bank	B
Pins	61, 63, 65, 69, 71, 75, 77, 81, 83, 87, 89, 93, 95, 101, 103, 105
Design Instruction	<p>The Astro Carrier fully supports the HDMI 2.0 interface from the Jetson TX2/TX2i module.</p> <p>All required circuitry is placed on the Astro Carrier. Route direct to header/connector/device</p>

Serial – HDC

The Astro Carrier features one display output interface using HDMI 2.0.

Function	HDMI
Function	Serial
Location	P2
HDC Bank	C
Pins	UART0 (/dev/ttyTHS2 within Linux for Tegra) – 135, 137, 141, 143 UART1: Default Serial Console (/dev/ttyS0 within Linux for Tegra) – 123, 125, 129, 131
Design Instruction	+/- 5.5V No additional circuitry required Transceiver placed on the Astro Carrier Route direct to header/connector/device

Serial Configuration

Two Serial UART Links from the Jetson™ TX2/TX2i Module are routed into an Exar SP336E Transceiver. This enables the various selectable serial outputs (RS-232/RS-485). To configure the setting, the appropriate configuration of the Serial Selection DIP Switch (SW1) is required. Please refer to the Exar SP336E datasheet for additional details.

Locked/Hardwired Configuration

The Astro Carrier comes populated with a control DIP Switch (SW1). The default setting for the serial configuration on SW1 is Dual RS-232.

Dual RS-232

Switch SW1	Position	Description
A	OFF	Mode 0 Selection - RS-232 Selection
B	OFF	Serial Link 0 - RX+ BIAS
C	OFF	Mode 1 Selection - RS-232 Selection
D	OFF	Serial Link 0 - RX- BIAS
E	OFF	Serial Link 1 - RX+ BIAS
F	OFF	Serial Link 1 – RX- BIAS

Serial 0 RS-232/Serial 1 RS-485

Switch SW1	Position	Description
A	OFF	Mode 0 Selection - RS-232 Selection
B	OFF	Serial Link 0 - RX+ BIAS
C	ON	Mode 1 Selection - RS-485 Selection
D	OFF	Serial Link 0 - RX- BIAS
E	USER	Serial Link 1 - RX+ BIAS
F	USER	Serial Link 1 – RX- BIAS

Dual RS-485

Switch SW1	Position	Description
A	ON	Mode 0 Selection - RS-485 Selection
B	USER	Serial Link 0 - RX+ BIAS
C	OFF	Mode 1 Selection - RS-485 Selection
D	USER	Serial Link 0 - RX- BIAS
E	USER	Serial Link 1 - RX+ BIAS
F	USER	Serial Link 1 – RX- BIAS

Dual Disable

Switch SW1	Position	Description
A	ON	Mode 0 Selection - Disable Selection
B	XX	Serial Link 0 - RX+ BIAS
C	ON	Mode 1 Selection - Disable Selection
D	XX	Serial Link 0 - RX- BIAS
E	XX	Serial Link 1 - RX+ BIAS
F	XX	Serial Link 1 – RX- BIAS

10/100/1000 Ethernet (GBE) – HDC

Function	Gigabit Ethernet
Location	P2
HDC Bank	A
Pins	GBE0 – 38, 42, 44, 46, 48, 50, 52, 54, 56, 60, 62, 64, 66 GBE1 – 8, 10, 12, 14, 18, 20, 22, 24, 26, 28, 30, 32, 36
Design Instruction	<p>An in-line buffer (Recommended Part: NC7WZ04P6X) with Resistors for the GBE0 LED Pins (ACT#, LINK#, LINK100#, LINK1000#) is required</p> <p>An in-line buffer (Recommended Part: NC7WZ16P6X) with Resistors for the GBE1 LED Pins (ACT#, LINK#, LINK100#, LINK1000#) is required</p> <p>No additional circuitry required for MDI pins Route MDI connections direct to header/connector/device</p>

Camera Serial Interface (CSI-2) – HDC

The Astro Carrier routes one CSI-2 (two lane) interface to the HDC. This is the CSI port 4 from the Jetson™ TX2/TX2i module.

Function	Camera Serial Interface
Location	P2
HDC Bank	C
Pins	134, 136, 140, 142, 146, 148
Design Instruction	Similar to the Jetson™ TX2/TX2i development kit, the CSI interface is directly connected between the Jetson™ TX2/TX2i module and the HDC on the Astro carrier. There is no EMI/ESD protection along the signal path. It is recommended to include this on the Breakout Board.

Power Input – HDC

The Astro Carrier accepts a single power input to power all on-board devices. While an input range of +7.5V to +14.0V is acceptable, a single +12.0V input is nominal for operation.

Function	Power Input
Location	P2
HDC Bank	C
Pins	BLADE_C
Design Instruction	Reverse Polarity protection recommended on Breakout Board Design LC Filter placed on Astro Carrier

+3.3V Power Output – HDC

The Astro Carrier generates a +3.3V rail that is available for use on Breakout Board Designs. A maximum of 500mA is available for use.

Function	+3.3V Power Output
Location	P2
HDC Bank	A
Pins	BLADE_A
Design Instruction	The provided +3.3V can be used for any circuitry, including LEDs, on the Breakout Board.

+1.8V Power Output – HDC

The Astro Carrier generates a +1.8V rail that is available for use on Breakout Board Designs. A maximum of 500mA is available for use.

Function	+1.8V Power Output
Location	P2
HDC Bank	B
Pins	110, 112
Design Instruction	The provided +1.8V is intended to provide power to any camera sensor that is connected to the CSI interface on a Breakout Board.

TYPICAL INSTALLATION

1. Ensure all external system power supplies are off.
2. See the assembly diagram below. It is recommended to use thread locker and to torque the screws to 5.2 in-lb.

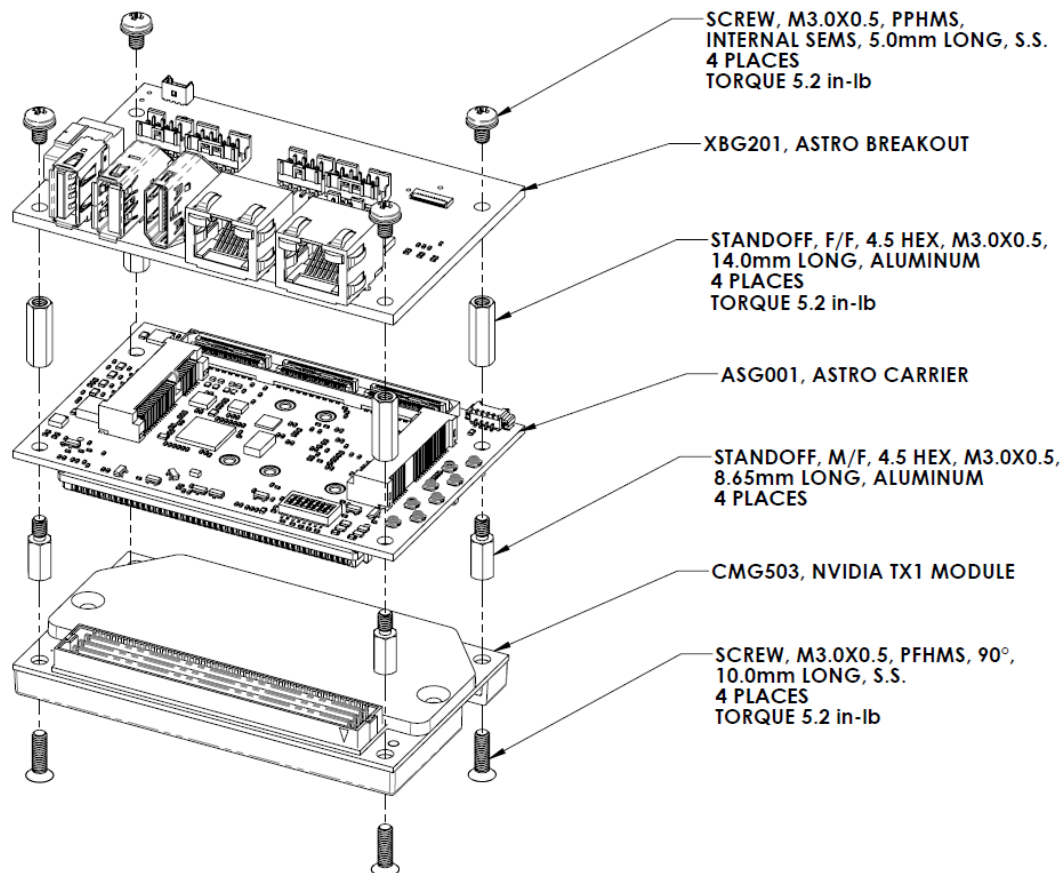

Note: The 8.65mm M/F stand-off comes with thread locker already applied. This will increase the resistance when fastening this stand-off to the assembly. Therefore it is recommended to use a 3/16 socket driver during assembly.

3. Connect your cables. At a minimum this would include:
 - a. Power cable to the input power connector
 - b. Connect a video display cable or use the serial console
 - c. Keyboard and mouse via USB

4. To connect power, the XBG201 or XBG206 Breakout Board comes with a power screw terminal installed on the power connector. Connect your power wires into this terminal and install it onto the Breakout Board to provide power to the system. **DO NOT** power up your system by plugging in live power.

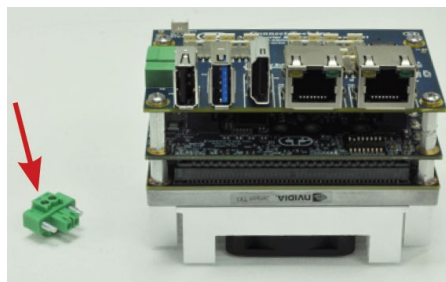

5. Apply power. The system should automatically boot up without any need to push the power button.

POWER SUPPLY

Connect Tech offers 12V 2A power supplies preconfigured for the XBG201 or XBG206 breakout board. It is supplied by a standard AC line cord and has a cable length of approximately 1.5m. Contact our sales department about the **MSG062** or **MSG070** for more details. [View the MSG062 drawing.](#)

ON-BOARD INDICATOR LEDS

The Astro Carrier has 2 on-board indicator LEDs.

LED	Description
D10	Carrier Stand-by Power Good: indicates the standby power is good.
D11	Carrier Power Good: indicates all onboard power supplies are properly regulated. It is only off in the event one of the onboard power supplies is malfunctioning while the carrier power is enabled.

CURRENT CONSUMPTION DETAILS

Below are the maximum ratings of the Astro Carrier.

Maximums	Watts
Theoretical absolute maximum total draw of all functionality on the Astro Carrier Board	10

Below are measurements taken with the Astro Carrier (ASG001) running in various configurations with the XBG201/XBG206 Breakout Board. Values will change depending on what Astro Breakout Board is installed. Measurements also include the Jetson™ TX2/TX2i Module. No mSATA or miniPCIe modules were installed while taking these measurements. All measurements were taken in a lab environment with an ambient temperature of 25 degrees Celsius.

Maximums	Watts
Module Installed, booted into Ubuntu, idle	7.2
Module Installed, booted into Ubuntu, running a Feature Tracker Demo	14.3
Module Installed, booted into Ubuntu, running a NVStreamer Demo with a USB camera and 1080p video.	14.6

SOFTWARE / BSP DETAILS

All Connect Tech NVIDIA Jetson TX2/TX2i based products are built upon a modified Linux for Tegra (L4T) Device Tree that is specific to each CTI product.

WARNING: The hardware configurations of CTI's products differ from that of the NVIDIA supplied evaluation kit. Please review the product documentation and install ONLY the appropriate CTI L4T BSPs. Failure to follow this process could result in non-functional hardware.

Connect Tech's Custom L4T BSP (CTI-L4T)

Connect Tech offers a custom BSP to add additional peripheral support on CTI's Jetson Carrier Boards. The CTI-L4T can be downloaded directly from Connect Tech here:

<https://connecttech.com/product/rudi-embedded-system-for-nvidia-jetson-tx2-tx1/>

BSPs, supporting documentation and release notes can be found at:

<https://www.connecttech.com/jetson>

<https://connecttech.com/resource-center/cti-l4t-nvidia-jetson-board-support-package-release-notes/>

NVIDIA Linux For Tegra (L4T)

The Astro Carrier Board is designed to be used with the stock **NVIDIA Linux For Tegra (L4T) Builds**. However, the Connect Tech Board Support Package is required for full functionality.

NVIDIA’s L4T can be downloaded directly from NVIDIA here:

<https://developer.nvidia.com/embedded/>

NVIDIA Jetpack for L4T

The JetPack for L4T is an on-demand all-in-one package that bundles and installs all software tools required to develop for the NVIDIA’s TX2/TX2i Platform with Connect Tech’s Jetson Carrier Boards. JetPack includes host and target development tools, APIs and packages (OS images, tools, APIs, middleware, samples, documentation including compiling samples) to enable developers to jump start their development environment for developing with the Jetson Embedded Platform. The latest release of JetPack runs on an Ubuntu 14.04 Linux 64-bit host system and supports both the latest Jetson TX2/TX2i Development Kit and Jetson TK1 Development Kit.

NVIDIA’s Jetpack can be downloaded directly from NVIDIA here:

<https://developer.nvidia.com/embedded/jetpack>

THERMAL DETAILS

The Astro Carrier Board has an Operating Temperature Range of -40°C to +85°C.

However, it is important to note that the NVIDIA Jetson TX2 Modules have its own properties separate to that of the Astro Carrier Board. The NVIDIA Jetson TX2i matches the Astro Operating Temperature Range of -40°C to +85°C.

Customer responsibility requires proper implementation of a thermal solution that maintains the TX2/TX2i SoC and Thermal Transfer Plate (TTP) temperatures below the specified temperatures (shown in the tables below) under the maximum thermal load and system conditions for their use case.

Jetson TX2i Thermal Specifications

Parameter	Value	Units
Maximum TTP operating temperature	85	°C
Recommended Tegra X2 operating temperature limit	T.cpu = 95.5	°C
	T.gpu = 95.5	°C
Tegra X2 maximum operating temperature limit	T.cpu = 101	°C
	T.gpu = 101	°C
	T.diode = 110	°C

Jetson TX2 Thermal Specifications

Parameter	Value	Units
Maximum TTP operating temperature	80	°C
Recommended Tegra X2 operating temperature limit	T.cpu = 95.5	°C
	T.gpu = 93.5	°C
Tegra X2 maximum operating temperature limit	T.cpu = 101	°C
	T.gpu = 101	°C

NVIDIA provides complete Thermal Design Guides, which include all of the information required to implement a complete thermal solution for the Jetson TX2 or TX2i Module. The Thermal Design Guides can be downloaded here:

Jetson TX2i:

<https://developer.nvidia.com/embedded/dlc/jetson-tx2i-thermal-design-guide>

Jetson TX2:

<https://developer.nvidia.com/embedded/dlc/jetson-tx2-thermal-design-guide>

MECHANICAL DRAWINGS

3D Model Download

A complete **3D STEP Model** file of Astro Carrier can be downloaded here:

https://www.connecttech.com/ftp/3d_models/ASG001_3D_MODEL.zip

Weight

The ASG001 (Astro Carrier) has a weight of 46 grams with all stand-offs installed.

Astro Carrier Outline and Dimensions

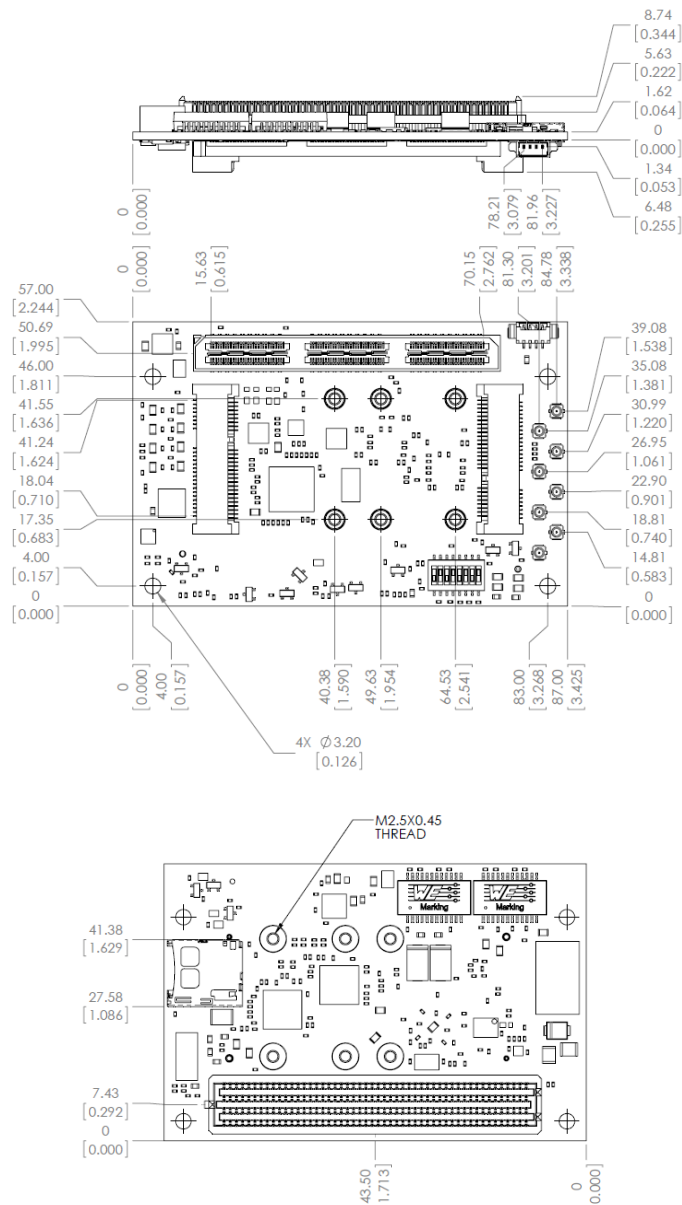

Astro System Stacking Height

The images below include the Jetson™ TX2/TX2i, Astro Carrier (ASG001), and Astro Breakout Board (XBG201/XBG206).

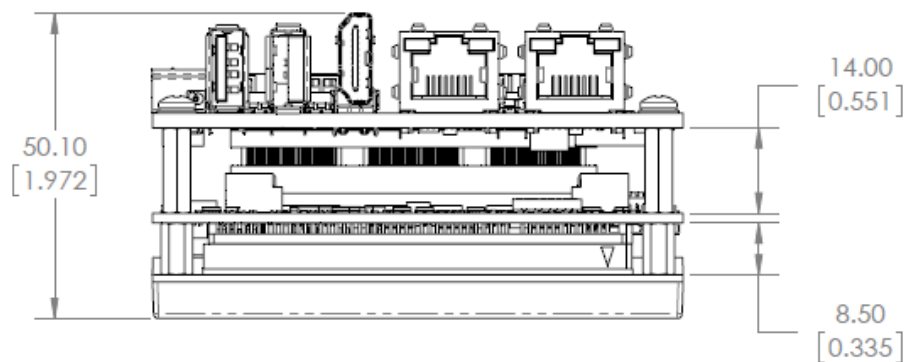
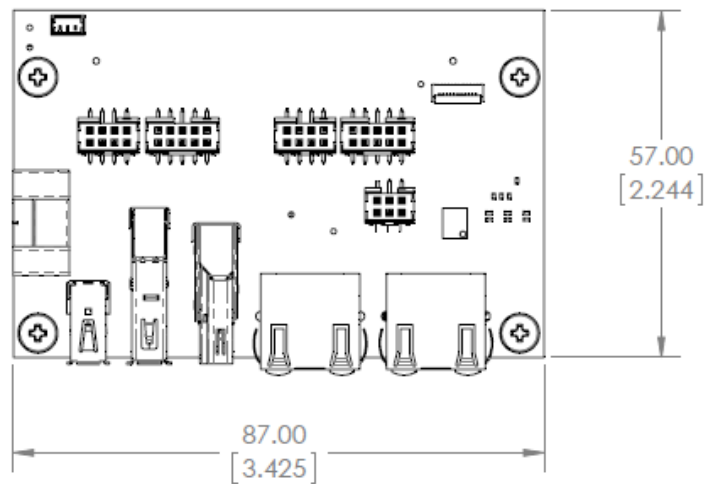
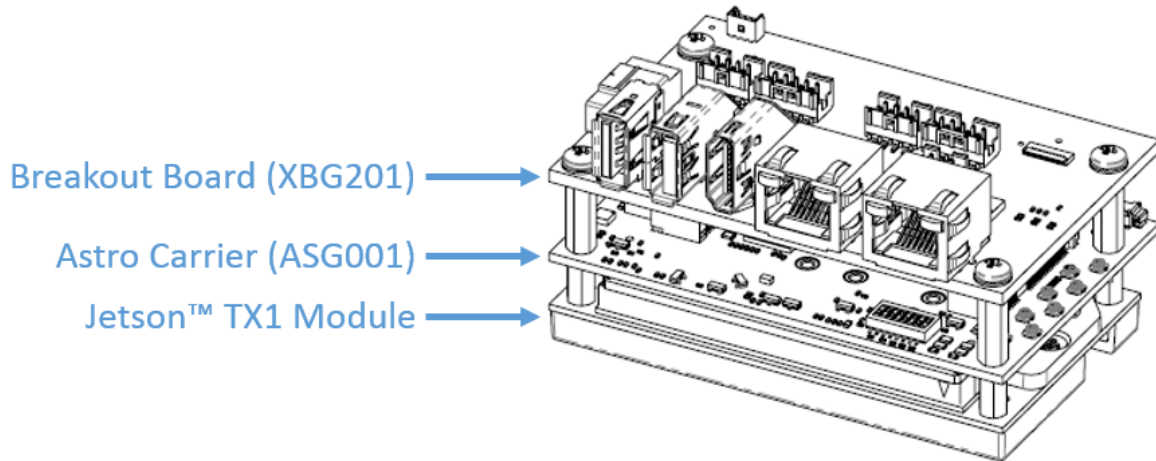

CTI BREAKOUT BOARDS

The following table summarizes the Astro Breakout Boards that are currently available from Connect Tech Inc.

Available Breakout Boards

Specifications	
Breakout Board	Astro Breakout Board for NVIDIA Jetson TX2 (XBG201), Astro Breakout Board for NVIDIA Jetson TX2i (XBG206)
Compatibility	ASG001
Dimensions	87mm x 57mm (3.43" x 2.24")
Mini-PCIe/mSATA	1x Mini-PCIe Full or Half 1x mSATA Half Size
Display	1x HDMI
Serial	2x RS-232/RS-485 Header
USB	1x USB 3.0 1x USB 2.0
Ethernet	2x RJ-45 Gigabit Ethernet
Audio	Stereo Output Header
GPIO	4x GPIO Header
Power Requirements	XBG201: +9V to +36V Input XBG206: +12V to +36V Input
Operating Temperature	-40°C to +85°C
Weight	51 grams
Image	

Breakout Board XBG201, XBG206 Technical Details

The following section provides technical details of the XBG201 or XBG206 Breakout Boards.

XBG201 Connector Locations

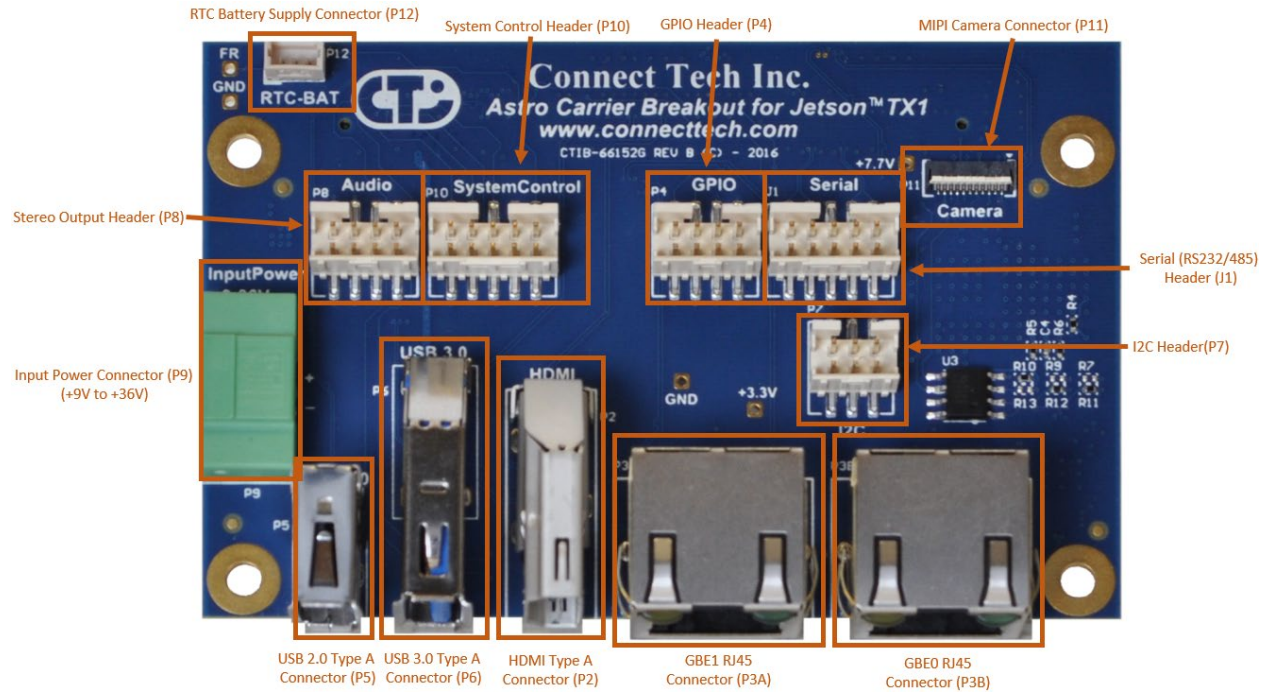

Stereo Output Header

Function	Stereo Output Audio Header	
Location	P8	
Type	FCI Minitek Double Row 4 x 2	
P/N	98424-G52-08LF	
Mating	10073599-008LF – Manufacturer: FCI	
Cable	CBG118	
Pinout	Pin	Description
	1	-
	2	-
	3	-
	4	-
	5	GND
	6	GND

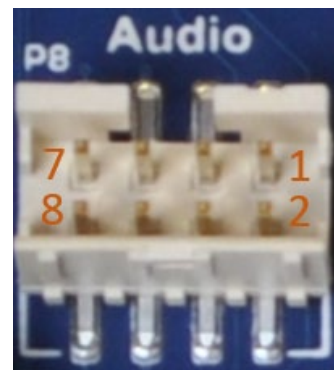

	7	HP OUT R	
	8	HP OUT L	

RTC Battery Header

Function	RTC Battery Header	
Location	P12	
Type	PicoBlade	
P/N	53047-0310	
Mating	51021-0300 - Manufacturer: Molex	
Cable	N/A	
Pinout	Pin	Description
	1	+3V
	2	-
	3	GND



Input Power Connector

Function	Input Power Connector	
Location	P9	
Type	Pluggable Terminal Contact	
P/N	1843790	
Mating	1847055 (included with the Breakout Board)	
Cable	N/A	
Pinout	Pin	Description
	1	+
	2	GND (-)
	Input Voltage Range: +9V to +36V The positive and negative terminals are clearly labelled on the PCB silkscreen.	



System Control Header

Function	System Control Header	
Location	P10	
Type	FCI Minitek Double Row 5 x 2	
P/N	98424-G52-10LF	
Mating	10073599-010LF – Manufacturer: FCI	
Cable	CBG190	
Pinout	Pin	Description
	1	Power Button#
	2	GND
	3	Main Reset#
	4	GND
	5	Secondary Reset#
	6	GND
	7	SLEEP#
	8	GND
	9	BATLOW#
	10	GND

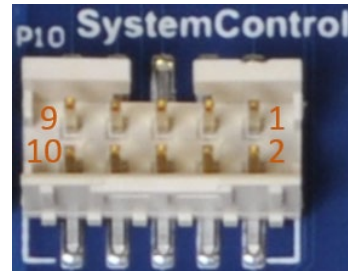

Force Recovery

Function	Force Recovery
Location	Top Left Corner of the Board
Type	Test Point
P/N	N/A
Mating	N/A
Cable	N/A
Details	To place the system into Force Recovery mode, short the FR and GND test points together.



GPIO Header

Function	Stereo Output Audio Header	
Location	P4	
Type	FCI Minitek Double Row 4 x 2	
P/N	98424-G52-08LF	
Mating	10073599-008LF – Manufacturer: FCI	
Cable	N/A	
Pinout	Pin	Description
	1	GPIO8
	2	GND
	3	GPIO9
	4	GND
	5	GPIO_EXPO_INT
	6	GND
	7	GPIO EXP1 INT
8	GND	
Note for software development: Please reference our GPIO KDB for TX2/TX2i values.		

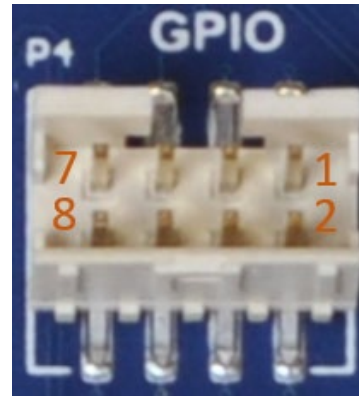

I2C Header

Function	I2C Header	
Location	P7	
Type	FCI Minitek Double Row 3 x 2	
P/N	98424-G52-06LF	
Mating	10073599-006LF – Manufacturer: FCI	
Cable	CBG112	
Pinout	Pin	Description
	1	I2C_GP1_SCL
	2	GND
	3	I2C_GP1_SDA
	4	-
5	-	

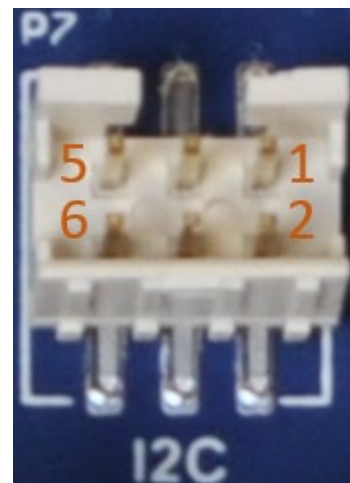

	6	-	
	The I2C bus corresponds to bus 1 within Linux for Tegra		

Serial (RS-232/485) Header

Function	Serial (RS-232/485) Header		
Location	J1		
Type	FCI Minitek Double Row 5 x 2		
P/N	98424-G52-10LF		
Mating	10073599-010LF – Manufacturer: FCI		
Cable	CBG111		
Pinout	Pin	Signal	Description
	1	232TX0/485TX0+	RS-232 0 Transmit / RS-485 0 Transmit +
	2	232RX0/485RX0+	RS-232 0 Receive / RS-485 0 Receive +
	3	485TX0-	RS-485 0 Transmit -
	4	485RX0-	RS-485 0 Receive -
	5	232/485-GND0	Port 0 Ground
	6	232/485-GND1	Port 1 Ground
	7	232TX1/485TX1+	RS-232 1 Transmit / RS-485 1 Transmit +
	8	232RX1/485RX1+	RS-232 1 Receive / RS-485 1 Receive +
	9	485TX1-	RS-485 1 Transmit -
	10	485RX1-	RS-485 1 Receive -
UART0 = /dev/ttyTHS2 within Linux for Tegra UART1 = /dev/ttyS0 within Linux for Tegra			

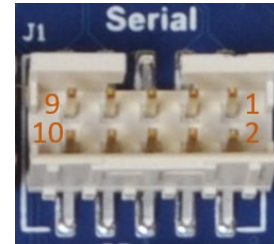

MIPI Camera Connector

Function	MIPI Camera Connector			
Location	P11			
Type	FPC Type Connector 0.3mm Pitch			
P/N	AYF332335			
Mating	CSI-2 Camera Sensor			
Pinout	Pin	Description	Pin	Description
	1	+18V	2	+1.8V
	3	GND	4	CSI4_D0_P
	5	CSI4_D0_N	6	GND
	7	CSI4_CLK_P	8	CSI4_CLK_N
	9	GND	10	CSI4_D1_P
	11	CSI4_D1_N	12	GND
	13	CAM0_MCLK	14	CAM0_PWRDN
	15	GND	16	I2C_GP1_SDA
	17	I2C_GP1_CLK	18	CAM0_RST
	19	-	20	GND
	21	+2.8V	22	-
	23	GND	-	-
<p>Note: This is the same connector used on the TX2/TX2i developer kit. This connector can accept cables with contacts facing both up and down. Ensure you are installing the cable correctly by verifying with the pinout above. Failure to do so may damage the carrier.</p>				



Astro Breakout Board XBG201 Outline and Dimensions

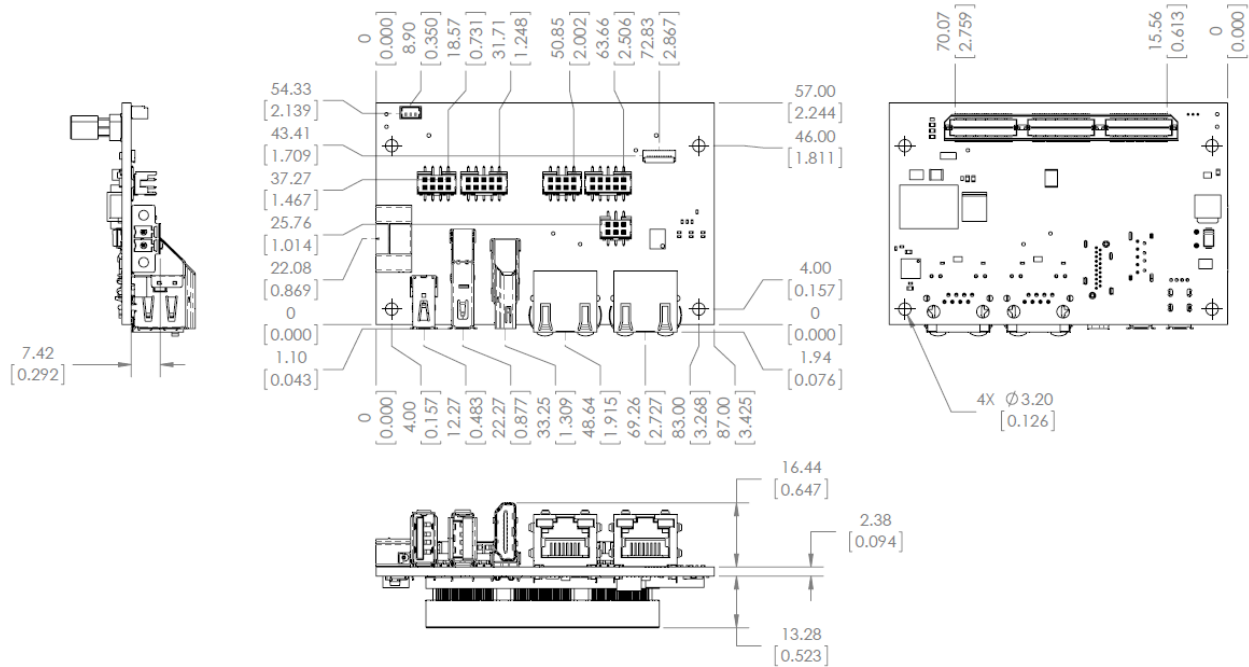

Custom Breakout Board

If a user wishes to create their own breakout board to connect to the Astro Carrier, Connect Tech Inc. has prepared a reference design package. In addition, Connect Tech Inc. also offers a quick turn, low-cost design service to create your custom breakout board. Please contact sales for more information at sales@connecttech.com.

Reference Design Package – OEM Astro Breakout Board

[Click here to download the Reference Design Package](#)

CABLES

The following table summarizes the Astro Breakout Board (XBG201/XBG206) cables available.

Available Cables

The following table shows the available cables for the XBG201 or XBG206 Breakout Board. These cables are all included in a cable kit which can be purchased. To purchase the cable kit please use the cable kit number CKG041.

Drawing No.	Part No.	Description	Cable Kit CKG041 (QTY)
<u>CTIC-00498</u>	CBG134	10-pin Minitex to flying Lead Cable (for System Control Header)	1
<u>CTIC-00430</u>	CBG111	Dual DB-9 Panel Mount to 10-Pin Minitex Cable	1
<u>CTIC-00431</u>	CBG112	6-Pin Minitex to Flying Lead Cable (for I2C Header)	1
<u>CTIC-00434</u>	CBG118	Dual Audio (uses HP out only) to 8-Pin Minitex Cable	1
<u>CTIC-00477</u>	CBG136	CR2032 RTC Battery w/ 3-pin Connector Cable Assembly - 6032101013	1
<u>CTIC-00570</u>	MSG062	North American Power Supply Unit for Astro	0
TBD	MSG070	Multi-Region Power Supply Unit for Astro	0