

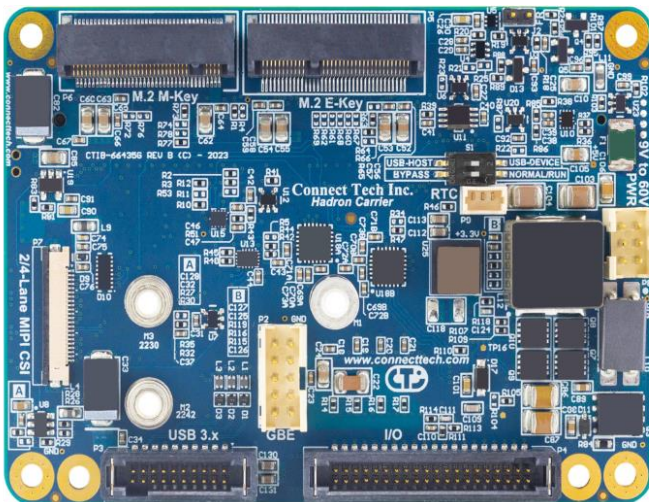

**Connect Tech Inc.**  
Embedded Computing Experts

# USERS GUIDE

NGX012



NGX024

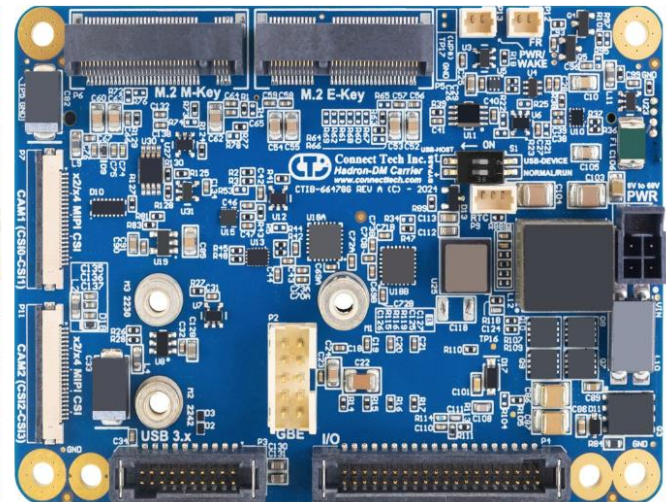

## Hadron/ Hadron DM Carrier

CTIM-00088(0.10) 2024-09-10



ELITE  
PARTNER

# TABLE OF CONTENTS

<b>Table of Contents .....</b>	<b>2</b>
<b>Preface .....</b>	<b>4</b>
Disclaimer .....	4
Customer Support Overview.....	4
Contact Information .....	4
Limited Product Warranty .....	5
Copyright Notice.....	5
Trademark Acknowledgment.....	5
ESD Warning .....	6
<b>Revision History .....</b>	<b>7</b>
<b>Introduction .....</b>	<b>8</b>
Product Feature and Specifications.....	8
Part Numbers / Ordering Information.....	9
<b>Product Overview .....</b>	<b>9</b>
Block Diagram.....	9
Connector Locations .....	10
Connector Summary .....	12
Jumper and Switch Summary .....	12
<b>Detailed Feature Description.....</b>	<b>13</b>
Jetson Orin™ / Xavier™ NX Module Connector.....	13
10/100/1000 Ethernet Connectors.....	14
USB 3.1 Connector .....	15
I/O Header.....	16
M.2 E-Key – Wi-Fi and Bluetooth Expansion Port .....	17
M.2 M-Key – NVMe .....	18
MIPI CSI-2 Connectors .....	18
Power Header.....	20
3-Pin RTC Battery Connector.....	21
+5V Fan Connector.....	21
Reset & Recovery Jumper .....	22
USB Host / Device Mode and Power Switch .....	22
USB Host / Device Mode and Power Switch .....	23
LED Indicators.....	23
<b>Typical Installation .....</b>	<b>24</b>
<b>Mechanical Details .....</b>	<b>25</b>
<b>Thermal Details.....</b>	<b>34</b>
<b>Cable Information.....</b>	<b>34</b>
Cable Components:.....	35

<b>Connect Tech Custom Thermal Solutions .....</b>	<b>36</b>
<b>Current Consumption Details .....</b>	<b>37</b>
<b>Software / BSP Details.....</b>	<b>37</b>
<b>Annexure I .....</b>	<b>38</b>
NGX012 vs NGX024.....	38

## PREFACE

### Disclaimer

The information contained within this user’s guide, including but not limited to any product specification, is subject to change without notice.

Connect Tech assumes no liability for any damages incurred directly or indirectly from any technical or typographical errors or omissions contained herein or for discrepancies between the product and the user’s guide.

### Customer Support Overview

If you experience difficulties after reading the manual and/or using the product, contact the Connect Tech reseller from which you purchased the product. In most cases the reseller can help you with product installation and difficulties.

In the event that the reseller is unable to resolve your problem, our highly qualified support staff can assist you. Our support section is available 24 hours a day, 7 days a week on our website at: <https://connecttech.com/support/resource-center/>. See the contact information section below for more information on how to contact us directly. Our technical support is always free.

### Contact Information

Contact Information	
<b>Mail/Courier</b>	Connect Tech Inc. Technical Support 489 Clair Road West Guelph, Ontario Canada N1L 0H7
<b>Contact Information</b>	<a href="mailto:sales@connecttech.com">sales@connecttech.com</a> <a href="mailto:support@connecttech.com">support@connecttech.com</a> <a href="http://www.connecttech.com">www.connecttech.com</a> Toll Free: 800-426-8979 (North America only) Telephone: +1-519-836-1291 Facsimile: 519-836-4878 (on-line 24 hours)
<b>Support</b>	Please go to the <a href="#">Connect Tech Resource Center</a> for product manuals, installation guides, device drivers, BSPs and technical tips.  Submit your <a href="#">technical support</a> questions to our support engineers. Technical Support representatives are available Monday through Friday, from 8:30 a.m. to 5:00 p.m. Eastern Standard Time.

## Limited Product Warranty

Connect Tech Inc. provides a one-year Warranty for this product. Should this product, in Connect Tech Inc.'s opinion, fail to be in good working order during the warranty period, Connect Tech Inc. will, at its option, repair or replace this product at no charge, provided that the product has not been subjected to abuse, misuse, accident, disaster or non-Connect Tech Inc. authorized modification or repair.

You may obtain warranty service by delivering this product to an authorized Connect Tech Inc. business partner or to Connect Tech Inc. along with proof of purchase. Product returned to Connect Tech Inc. must be pre-authorized by Connect Tech Inc. with an RMA (Return Material Authorization) number marked on the outside of the package and sent prepaid, insured and packaged for safe shipment. Connect Tech Inc. will return this product by prepaid ground shipment service.

The Connect Tech Inc. Limited Warranty is only valid over the serviceable life of the product. This is defined as the period during which all components are available. Should the product prove to be irreparable, Connect Tech Inc. reserves the right to substitute an equivalent product if available or to retract the Warranty if no replacement is available.

The above warranty is the only warranty authorized by Connect Tech Inc. Under no circumstances will Connect Tech Inc. be liable in any way for any damages, including any lost profits, lost savings or other incidental or consequential damages arising out of the use of, or inability to use, such product.

## Copyright Notice

The information contained in this document is subject to change without notice. Connect Tech Inc. shall not be liable for errors contained herein or for incidental consequential damages in connection with the furnishing, performance, or use of this material. This document contains proprietary information that is protected by copyright. All rights are reserved. No part of this document may be photocopied, reproduced, or translated to another language without the prior written consent of Connect Tech, Inc.

Copyright © 2024 by Connect Tech, Inc.

## Trademark Acknowledgment

Connect Tech, Inc. acknowledges all trademarks, registered trademarks and/or copyrights referred to in this document as the property of their respective owners. Not listing all possible trademarks or copyright acknowledgments does not constitute a lack of acknowledgment to the rightful owners of the trademarks and copyrights mentioned in this document.

## ESD Warning



Electronic components and circuits are sensitive to Electrostatic Discharge (ESD). When handling any circuit board assemblies including Connect Tech COM Express carrier assemblies, it is recommended that ESD safety precautions be observed. ESD safe best practices include, but are not limited to:

- Leaving circuit boards in their antistatic packaging until they are ready to be installed.
- Using a grounded wrist strap when handling circuit boards, at a minimum you should touch a grounded metal object to dissipate any static charge that may be present on you.
- Only handling circuit boards in ESD safe areas, which may include ESD floor and table mats, wrist strap stations and ESD safe lab coats.
- Avoiding handling circuit boards in carpeted areas.
- Try to handle the board by the edges, avoiding contact with components.

## REVISION HISTORY

Revision	Date	Changes
0.00	2023-03-21	Preliminary Release
0.01	2023-04-13	Added mechanical details, GPIO and USB information
0.02	2023-04-24	Update USB connector information
0.03	2023-05-26	Added list of components for cable assembly
0.04	2023-08-22	Camera I2C Pinout Updated Notes added for PCIe Gen# USB Pinout – Typo Fixed Host / Device Mode Switch – Description updated Product Feature and Description – USB Feature updated Typical Installation – Cable list updated Reset and Recovery Jumper – Description Updated CBG615 – Description updated
0.05	2023-09-25	USB Notes – Per port power values updated CBG686, XBG023 added to Cable Information Table
0.06	2023-10-19	Corrected M.2 M-Key typo
0.07	2024-01-31	Current Consumption: Details updated for Orin NX Mechanical Details: XBG023 Assembly instruction added SYS_ON LED notes updated
0.08	2024-05-14	Hadron Dual MIPI section added
0.09	2024-07-30	Corrected GPIO typo
0.10	2024-09-10	Added power connector information for NGX024

## INTRODUCTION

Connect Tech's Hadron platform brings a low cost deployable Jetson solution to the market. The Hadron's design includes 1x Gigabit Ethernet, 2 x USB 3.1 (when using NVIDIA® Jetson Orin™ NX), 1 x MIPI CSI-2 (4 lane), 4x GPIOs (2x PWM capable), 3x UART, 1x I2C, 1x SPI.

### Product Feature and Specifications

Feature	Description
<b>Module Compatibility</b>	NVIDIA® Jetson Xavier™ NX NVIDIA® Jetson Orin™ NX NVIDIA® Jetson Orin™ Nano
<b>Mechanical Dimensions</b>	82.65mm x 58.8mm (3.25" x 2.31")
<b>USB</b>	2x USB 3.1 Gen <ul style="list-style-type: none"> <li>1x USB 3.0 Host Only</li> <li>1x USB 3.0 Dual Function – Host / Device mode (Selectable by S1 switch)</li> </ul> Note – Dual Function port will be used when the system enters Force Recovery Mode
<b>MIPI Cameras</b>	1x 4-lane MIPI CSI-2 (2-lane support available with 22-to-15 pin FFC/FPC cable) Connector P/N: 54548-2271 22-pin FPC 0.5mm Pitch Connector
<b>Storage</b>	1x M.2 M-Key (NVMe) expansion slot (4 lane PCIe Gen 4) Support for 2242 and 2230 sized NVMe
<b>IO – Ethernet</b>	1x 10/100/1000BASE-T Uplink
<b>IO – UART Debug</b>	1x Debug UART (I/O header)
<b>IO – UART</b>	2x RS-232 (I/O header)
<b>IO – I2C</b>	1x I2C bus (I/O header)
<b>IO – SPI</b>	1x SPI bus (I/O header)
<b>IO – GPIO / PWM</b>	4x GPIO (I/O header) – 2x PWM Capable
<b>User Expansion</b>	1x M.2 Key-E Expansion Slot (1 lane PCIe Gen 3, USB 2.0) For Wi-Fi/Bluetooth modules
<b>RTC Battery</b>	3-Pin RTC Battery Connector
<b>Input Power</b>	+9V to +60V DC Wide Input Power
<b>Operating Temperature</b>	-25°C to +85°C (-13°F to +185°F)
<b>Weight</b>	49 grams
<b>Warranty and Support</b>	1 Year Warranty and Free Support



## Part Numbers / Ordering Information

Part Number	Description
NGX012	Hadron Carrier Only
NGX024	Hadron DM Carrier only
XBG023	USB 3.0 Breakout Board

## PRODUCT OVERVIEW

### Block Diagram

For **NGX012**

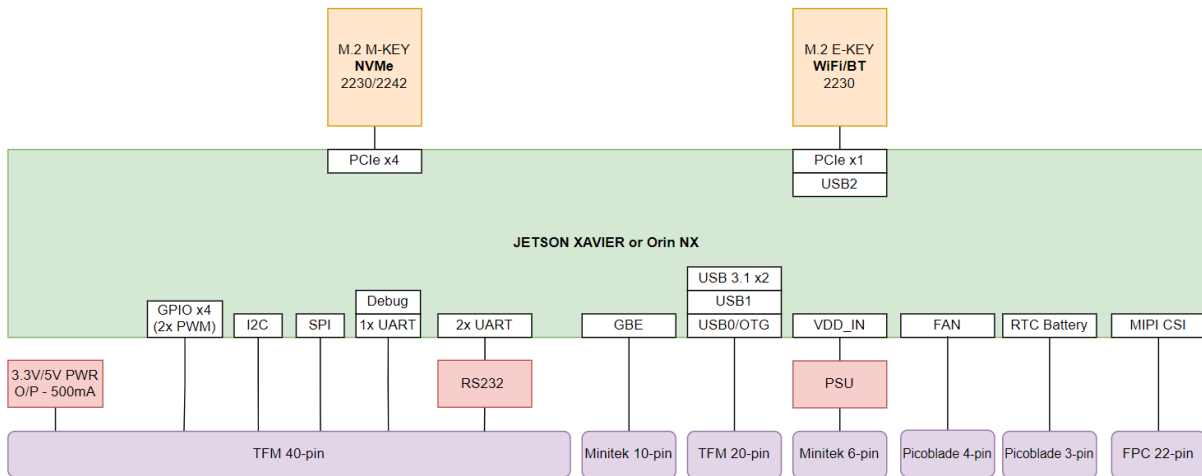

For **NGX024**

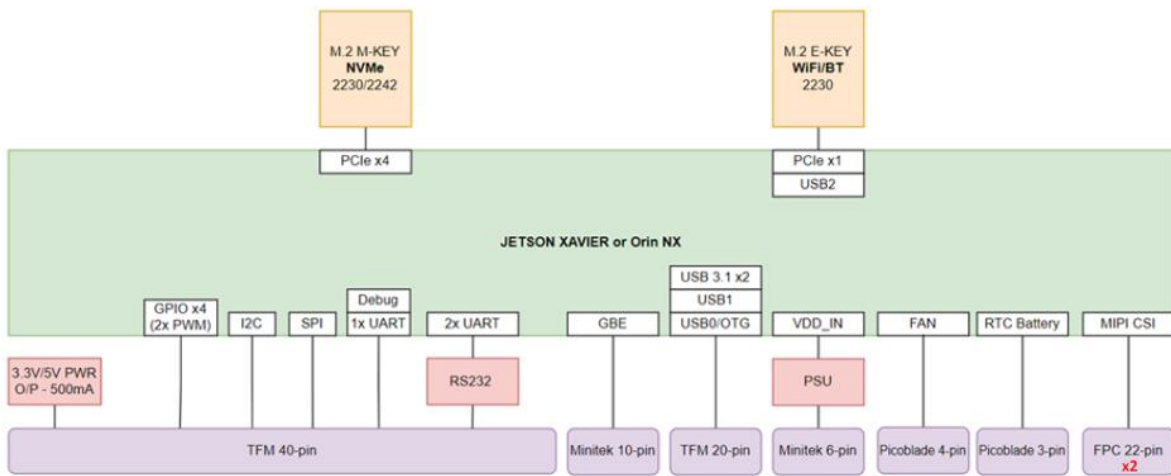

Connector Locations  
For NGX012

Top View

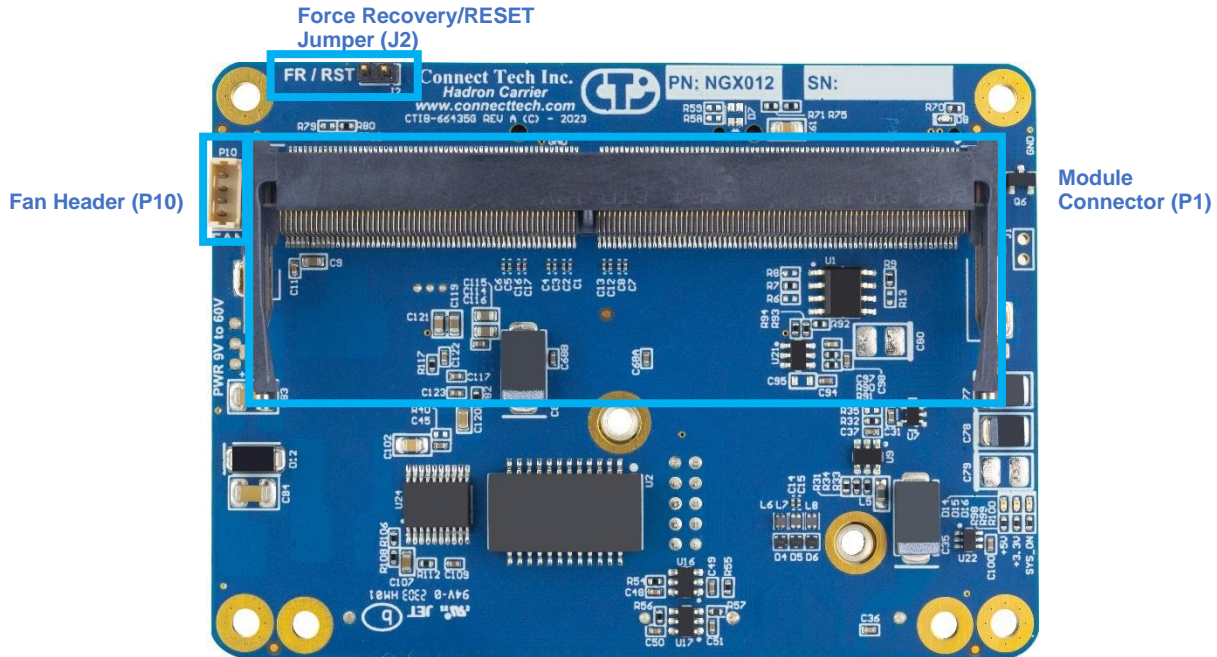

Bottom View

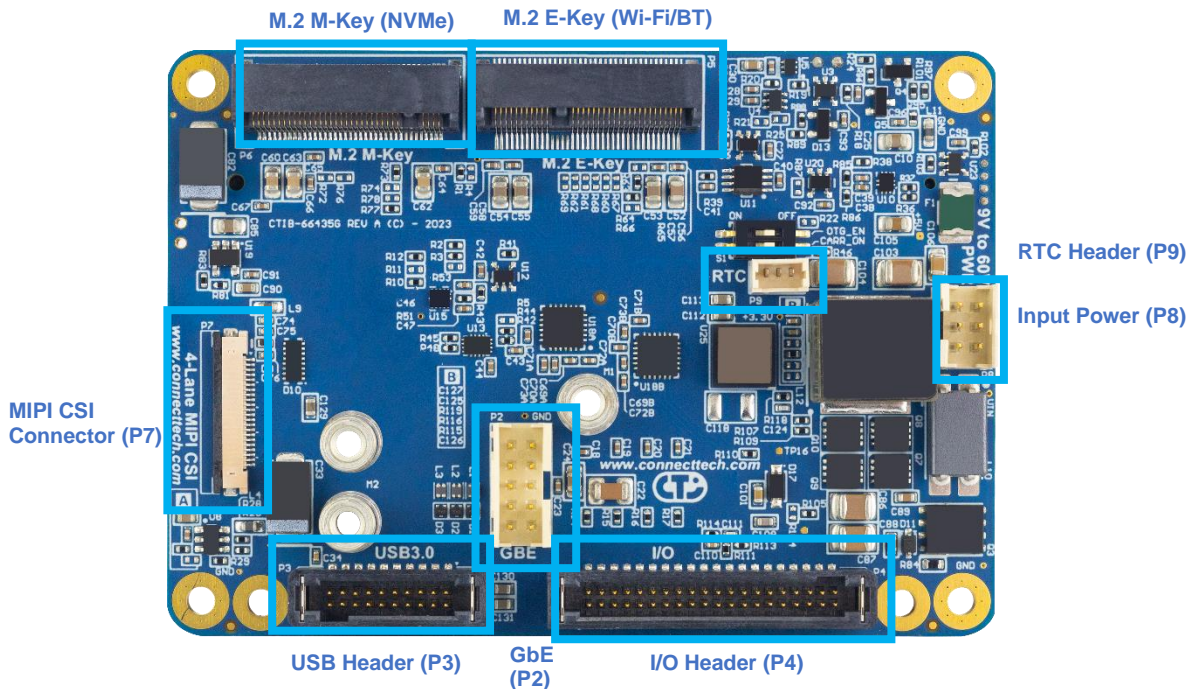

For NGX024

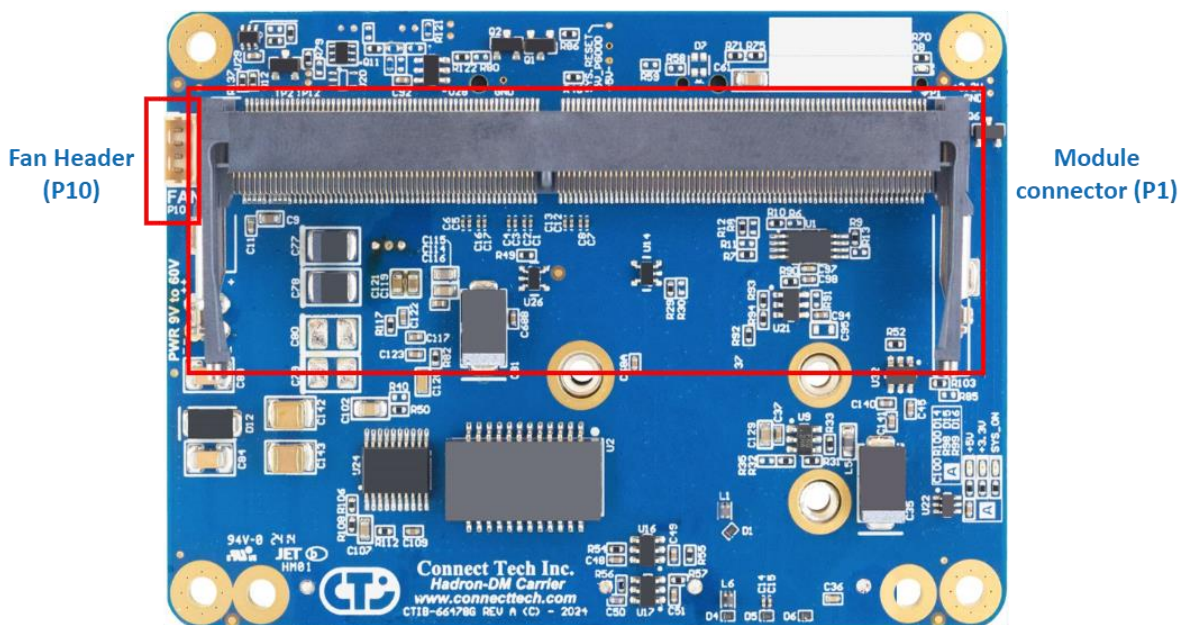
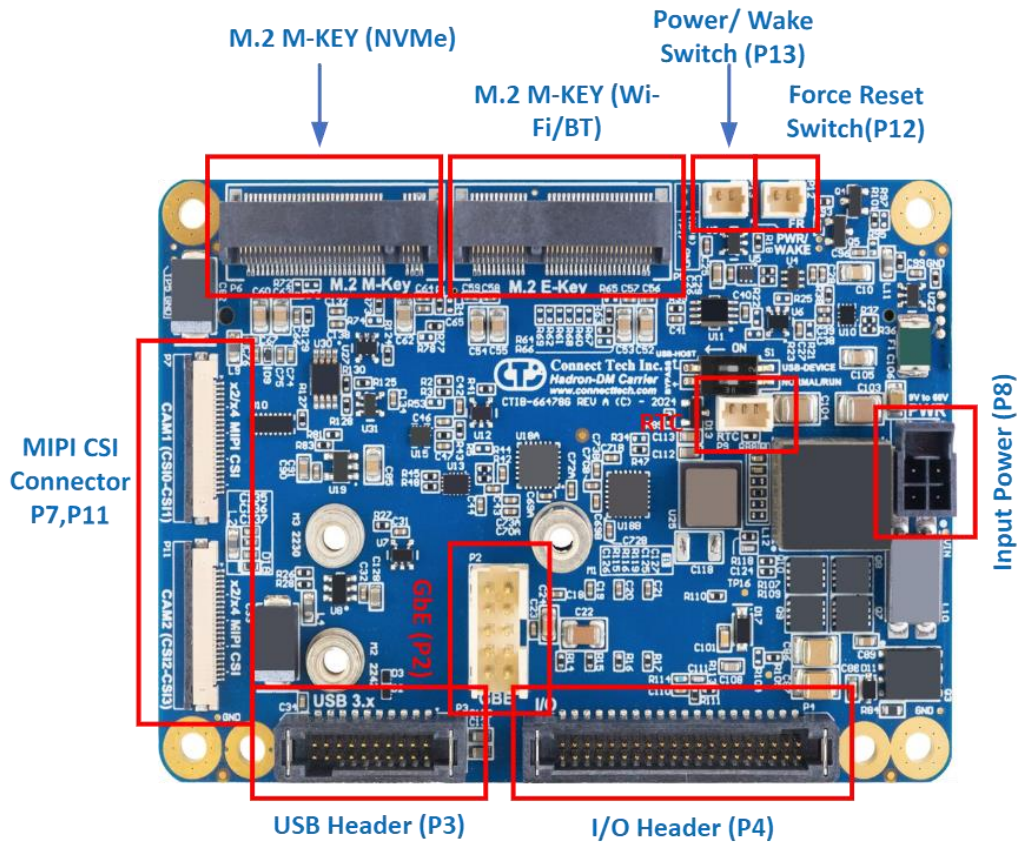

## Connector Summary

Designator	Connector	Description
P1	2309413-1	Module Board-To-Board Connector for: <ul style="list-style-type: none"> <li>• NVIDIA® Jetson Xavier™ NX</li> <li>• NVIDIA® Jetson Orin™ NX</li> </ul>
P2	98414-G06-10LF	GbE Connector
P3	TFM-110-02-L-D-WT	Dual Port USB 3.0 Connector
P4	TFM-120-02-L-D-WT	I/O Header
P5	10128797-004RLF	M.2 E-Key Connector
P6	10131758-001RLF	M.2 M-Key (NVMe) Connector
P7, P11 (NGX024 only)	54548-2271	4-lane MIPI CSI-2 Camera Connector
P8	98414-G06-06LF (NGX012) 1053101104 (NGX024)	Input Power Connector
P9	53047-0310	3-pin RTC Battery Connector
P10	53047-0410	5V Fan Connector
P13 (NGX024 only)	53047-0210	Power/ Wake Switch
P12 (NGX024 only)	53047-0210	Force Recovery/Reset Switch

## Jumper and Switch Summary

Designator	Connector	Description
S1	1571983-1	Host Mode / Device Mode Selection Switch
J2 (NGX012 only)	HTSW-102-08-G-S	Force Recovery/Reset Jumper Block

## DETAILED FEATURE DESCRIPTION

### Jetson Orin™ / Xavier™ NX Module Connector

#### Description

The NVIDIA® Jetson Orin™ / NVIDIA® Jetson Xavier™ NX processor and chipset are implemented on the Jetson Orin™ NX / Jetson Xavier™ NX Module. This connects to the Hadron/Hadron DM Carrier via a TE Connectivity DDR4 SODIMM 260 Pin connector.

Function	Description
<b>Location</b>	P1
<b>Type</b>	TE Connectivity DDR4 SODIMM 260 Pin
<b>Carrier Connector</b>	Part Number: 2309413-1 Manufacturer: TE Connectivity
<b>Mating Connector</b>	Jetson Orin™ NX / Jetson Xavier™ NX Module
<b>Pinout</b>	Refer to NVIDIA®'s Jetson Orin™ NX or Jetson Xavier™ NX System-On-Module datasheet for pinout details  <a href="https://developer.nvidia.com/embedded/downloads">https://developer.nvidia.com/embedded/downloads</a>
<b>Board-to-Module Standoff Height</b>	M2.5 x 6.57mm standoffs required between NVIDIA® Jetson Orin™ NX or NVIDIA® Jetson Xavier™ NX Module and Hadron/Hadron DM Carrier

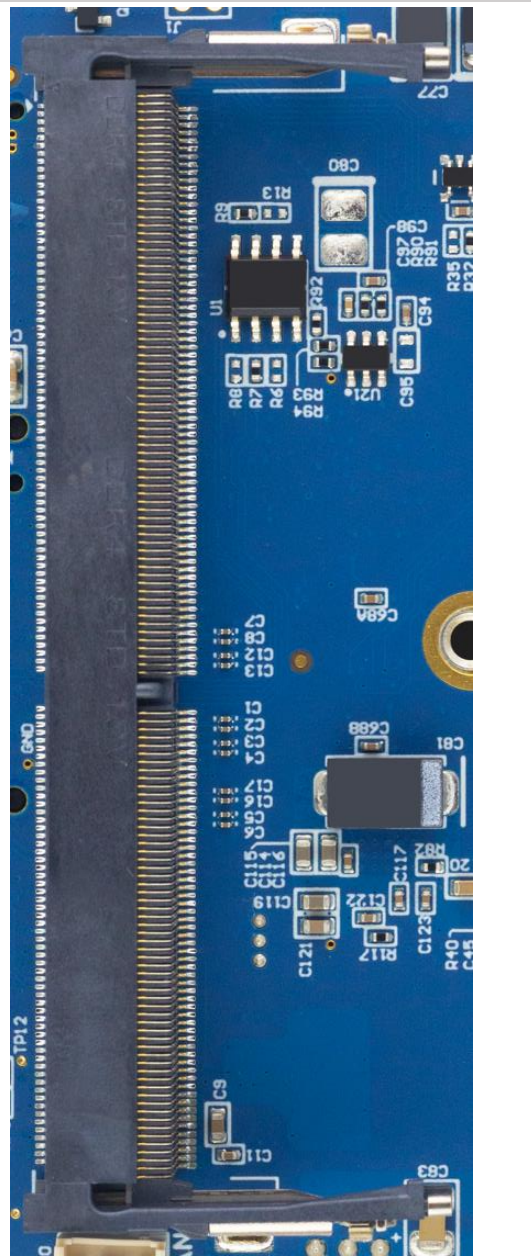

## 10/100/1000 Ethernet Connectors

### Description

The NVIDIA® Jetson Orin™ NX/ NVIDIA® Jetson Xavier™ NX module will allow internet communication via GbE connector as below.

Function	Description
<b>Location</b>	P2
<b>Ethernet Usage</b>	Jetson Onboard Ethernet
<b>Type</b>	10 pin RA connector
<b>Carrier Connector</b>	Part Number: 98414-G06-10LF Manufacturer: Amphenol ICC
<b>Mating Connector</b>	90311-010LF
<b>Mating CTI Cable</b>	CBG117
Pinout	
<b>Pin 1</b>	MDI0_N
<b>Pin 2</b>	MDI0_P
<b>Pin 3</b>	MDI1_N
<b>Pin 4</b>	MDI1_P
<b>Pin 5</b>	GBE_GND (Shield)
<b>Pin 6</b>	GBE_GND (Shield)
<b>Pin 7</b>	MDI2_N
<b>Pin 8</b>	MDI2_P
<b>Pin 9</b>	MDI3_N
<b>Pin 10</b>	MDI3_P

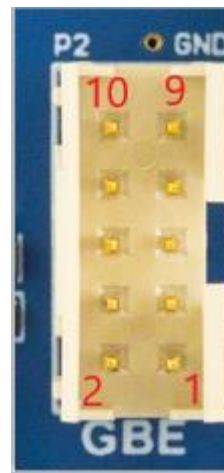

## USB 3.1 Connector

Function	Description
<b>Location</b>	P3
<b>Type</b>	Tiger Eye 20 Pin Connector, 0.05mm Pitch
<b>Carrier Connector</b>	Part Number: TFM-110-02-L-D-WT Manufacturer: Samtec
<b>Mating Cables</b>	CBG615 (USB 2.0 only), CBG686 (USB3.0), XBG023
Pinout	
<b>Pin 1</b>	GND
<b>Pin 2</b>	USB1_D_P
<b>Pin 3</b>	USB0_D_P
<b>Pin 4</b>	USB1_D_N
<b>Pin 5</b>	USB0_D_N
<b>Pin 6</b>	GND
<b>Pin 7</b>	GND
<b>Pin 8</b>	USB3_P1_TX_P
<b>Pin 9</b>	USB3_P0_TX_P
<b>Pin 10</b>	USB3_P1_TX_N
<b>Pin 11</b>	USB3_P0_TX_N
<b>Pin 12</b>	GND
<b>Pin 13</b>	GND
<b>Pin 14</b>	USB3_P1_RX_P
<b>Pin 15</b>	USB3_P0_RX_P
<b>Pin 16</b>	USB3_P1_RX_N
<b>Pin 17</b>	USB3_P0_RX_N
<b>Pin 18</b>	USB1 VBUS
<b>Pin 19</b>	USB0 VBUS
<b>Pin 20</b>	GND



Notes	Both ports will only be USB 3.1 capable when using Jetson Orin™ NX. Only Port 0 will be USB 3.1 capable when using Jetson Xavier™ NX.
	Maximum power available on each individual port is as below: Hadron Rev A, Rev B = 1A per port Hadron Rev C and onwards = 2A per port

## I/O Header

### Description

The Hadron/Hadron DM Carrier implements a TFM-120-02-L-D-WT Connector to allow access for additional GPIO and interfaces.

Function		Description			
<b>Location</b>		P4			
<b>Type</b>		Samtec 40Pin Connector, 1.27mm Pitch			
<b>Carrier Connector</b>		Part Number: TFM-120-02-L-D-WT Manufacturer: Samtec			
<b>Mating Cable/Connector</b>		CBG629 / SFSD-20-28C-G-12.00-SR Manufacturer: Samtec			
Pinout					
Description	Signal Name	Pins	Signal Name	Description	
Signal Ground	GND	1 2	GND	Signal Ground	
GPIO10	GPIO10	3 4	GPIO13	GPIO13 (PWM)	
GPIO11	GPIO11	5 6	GPIO12	GPIO12 (PWM)	
Signal Ground	GND	7 8	GND	Signal Ground	
+5V Power Out <sup>1</sup>	+5V_IO	9 10	+3.3V_IO	+3.3V Power Out <sup>1</sup>	
+5V Power Out <sup>1</sup>	+5V_IO	11 12	+3.3V_IO	+3.3V Power Out <sup>1</sup>	
Signal Ground	GND	13 14	GND	Signal Ground	
SPI0 Transmit	SPI0 MOSI	15 16	SPI0 SCK	SPI0 Clock	
SPI0 Receive	SPI0 MISO	17 18	SPI0 CS0	SPI0 Chip Select	
Signal Ground	GND	19 20	GND	Signal Ground	
RS-232_0 Request to Send	RS-232_0_RTS	21 22	RS-232_0_TX	RS-232_0 Transmit	
RS-232_0 Clear to Send	RS-232_0_CTS	23 24	RS-232_0_RX	RS-232_0 Receive	
Signal Ground	GND	25 26	GND	Signal Ground	
RS-232_1 Transmit	RS-232_1_TX	27 28	RS-232_1_RTS	RS-232_1 Request to Send	
RS-232_1 Receive	RS-232_1_RX	29 30	RS-232_1_CTS	RS-232_1 Clear to Send	
Signal Ground	GND	31 32	GND	Signal Ground	
I2C0 Clock	I2C 0 SCL	33 34	I2C 0 SDA	I2C0 Data	
Signal Ground	GND	35 36	GND	Signal Ground	
Debug UART RX	UART2_RX	37 38	UART2_TX	Debug UART TX	
Signal Ground	GND	39 40	GND	Signal Ground	

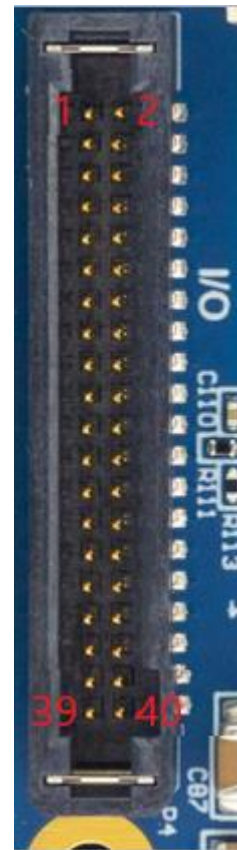



Xavier™ NX SW Interface Cross Reference		
Signal Name	Module ID	Controller ID
GPIO13	GPIO13	PR.00
GPIO10	GPIO10	PQ.01
GPIO11	GPIO11	PQ.06
GPIO12	GPIO12	PCC.04
GPIO13 (PWM)	C280000.pwm	pwmchip0
GPIO12 (PWM)	c340000.pwm	pwmchip1

Signal Name	SW/Dev ID	DTB ID
I2C0	i2c-1	i2c@c240000
RS232_0	/dev/ttyTHS1	serial@3110000
RS232_1	/dev/ttyTHS0	serial@3100000
SPI0	/dev/spidev0.0	spi@3210000

**Orin™ NX SW Interface cross Reference**

Signal Name	Module ID	Controller ID
GPIO13	GPIO13	PG.06
GPIO10	GPIO10	PEE.02
GPIO11	GPIO11	PQ.06
GPIO12	GPIO12	PN.01
GPIO13 (PWM)	32c0000.pwm	pwmchip2
GPIO12 (PWM)	3280000.pwm	pwmchip0

Signal Name	SW/Dev ID	DTB ID
I2C0	i2c-1	i2c@c240000
RS232_0	/dev/ttyTHS1	serial@3110000
RS232_1	/dev/ttyTHS0	serial@3100000
SPI0	/dev/spidev0.0	spi@3210000

  

Notes

- +3.3V and +5V power pins are outputs only, **DO NOT** feed power to these pins
- GPIO are 3.3V

## M.2 E-Key – Wi-Fi and Bluetooth Expansion Port

Function	Description
Location	P5
Type	67 Pin M.2 Connector with M2.5 Mounting Standoff
Connector	Part Number: 10128797-004RLF Manufacturer: Amphenol ICC
Pinout	As per the M.2 E-key specification
Notes	This port contains a x1 PCIe Gen 1 interface and one USB 2.0 interface. * PCIe Gen# is based on available equipment and their testing with Hadron/Hadron DM Carrier.

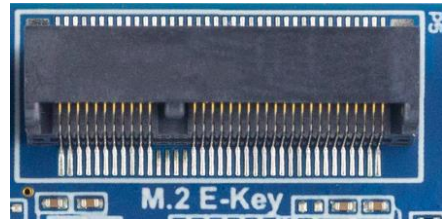

## M.2 M-Key – NVMe

Function	Description
<b>Location</b>	P6
<b>Type</b>	67 Pin M.2 Connector with M2.5 Mounting Standoff
<b>Connector</b>	Part Number: 10131758-001RLF Manufacturer: Amphenol ICC
<b>Pinout</b>	As per the M.2 M-key specification
<b>Notes</b>	Interface is x4 PCIe Gen 4. Support for M.2 2230 and 2242 sizes only. * PCIe Gen# is based on available equipment and their testing with Hadron/Hadron DM Carrier.



## MIPI CSI-2 Connectors

### Description

The NVIDIA® Jetson Orin™ NX/ NVIDIA® Jetson Xavier™ NX module will allow 2-lane or 4-Lane MIPI video input via the Right-Angle FPC connector. 2-lane support for 15-pin cameras if used with a 22-to-15 pin FFC/FPC cable.

Function	Description
<b>Location</b>	P7 (NGX012, NGX024) P11(NGX024)
<b>MIPI Lane usage</b>	CSI0
<b>Type</b>	MOLEX FPC Right Angle Connector 22 Pin
<b>Carrier Connector</b>	Part Number: 54548-2272 Manufacturer: Molex
Pinout	
<b>Pin 1</b>	+3.3V
<b>Pin 2</b>	CAM1_I2C_SDA
<b>Pin 3</b>	CAM1_I2C_SCL
<b>Pin 4</b>	GND
<b>Pin 5</b>	CAM1_MCLK
<b>Pin 6</b>	CAM1_PWDN
<b>Pin 7</b>	GND
<b>Pin 8</b>	CSI1_D1_P
<b>Pin 9</b>	CSI1_D1_N



<b>Pin 10</b>	GND
<b>Pin 11</b>	CSI1_D0_P
<b>Pin 12</b>	CSI1_D0_N
<b>Pin 13</b>	GND
<b>Pin 14</b>	CSI0_CLK_P
<b>Pin 15</b>	CSI0_CLK_N
<b>Pin 16</b>	GND
<b>Pin 17</b>	CSI0_D1_P
<b>Pin 18</b>	CSI0_D1_N
<b>Pin 19</b>	GND
<b>Pin 20</b>	CSI0_D0_P
<b>Pin 21</b>	CSI0_D0_N
<b>Pin 22</b>	GND



22-to-15 pin cable image reference



## Power Header

### Description

The Hadron/Hadron DM Carrier implements a Power Connector using 98414-G06-06LF from Amphenol FCI.

Function	Description (NGX012 Only)
Location	P8
Type	Amphenol FCI MiniTek Series Connector
Carrier Connector	98414-G06-06LF
Mating CTI Cable	CBG112
Pinout	
Pin 1	GND
Pin 2	GND
Pin 3	GND
Pin 4	+VIN
Pin 5	+VIN
Pin 6	+VIN



Function	Description (NGX024 Only)
Location	P8
Type	Molex Nano-Fit 2x2 Vertical Header
Carrier Connector	1053101104
Mating CTI Cable	CBG732
Pinout	
Pin 1	+VIN
Pin 2	+VIN
Pin 3	GND
Pin 4	GND



## 3-Pin RTC Battery Connector

### Description

The Hadron/Hadron DM Carrier implements a 3-Position Molex PicoBlade connector for connecting the RTC battery.

Function	Description
<b>Location</b>	P9
<b>Type</b>	Molex 3 Position 1.25mm PicoBlade Connector
<b>Carrier Connector</b>	Part Number: 53047-0310 Manufacturer: Molex
<b>Mating Connector</b>	Molex 51021-0300 PicoBlade Connector
<b>Mating CTI Cable</b>	CBG136
Pinout	
<b>Pin 1</b>	RTC Battery Positive (+ve)
<b>Pin 2</b>	Not Connect
<b>Pin 3</b>	RTC Battery Negative (-ve)



## +5V Fan Connector

### Description

The Hadron/Hadron DM Carrier implements a 4-Position Molex PicoBlade connector for active cooling capability.

Function	Description
<b>Location</b>	P10
<b>Type</b>	Molex 4 Position 1.25mm PicoBlade Connector
<b>Carrier Connector</b>	Part Number: 53047-0410 Manufacturer: Molex
<b>Mating Connector</b>	Molex 51021-0400 PicoBlade Connector
Pinout	
<b>Pin 1</b>	GND
<b>Pin 2</b>	+5V
<b>Pin 3</b>	FAN_TACH
<b>Pin 4</b>	FAN_PWM



## Reset & Recovery Jumper

### Description

The Hadron/ Hadron DM Carrier implements a dual functionality jumper block/ connector for both Reset and Recovery of the platform. To Reset the module, simply connect the two pins on the jumper/ connector momentarily. To put the Jetson module into Force Recovery mode, install a jumper and then power on the platform. After 10 seconds remove the jumper shunt and the device will now be in Force Recovery mode.

Once the device is in Force Recovery Mode, it can be detected using *lsusb* (or equivalent) command on the host computer.

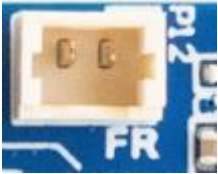
Function	Description		NGX012	NGX024
<b>Location</b>	J2 (NGX012)	P10 (NGX024)		
<b>Type</b>	Jumper Block	Molex 2 Position 1.25mm PicoBlade Connector		
<b>Carrier Connector</b>	HTSW-102-08-G-S Manufacturer: Samtec	53047-0210 Manufacturer: Molex		

**Note:** A full power cycle of the system must be performed after module flashing.

## USB Host / Device Mode and Power Switch

### Description

The Hadron DM Carrier implements a functionality connector for to wake the carrier from shutdown mode. To wake the module, simply connect the two pins on the connector momentarily.

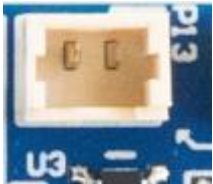
Function	Description		
<b>Location</b>	P13		
<b>Type</b>	1x2 TH 1.25mm (Molex –PicoBlade) connector		
	<b>Pin</b>	<b>Description</b>	
	1	SYS.SLEEP/WAKE#	
	2	GND	

## USB Host / Device Mode and Power Switch

Function	Description
Location	SW1
Type	TE Connectivity 1571983-1 DIP Switch
Carrier Connector	Part Number: 1571983-1 Manufacturer: TE Connectivity Product is shipped with both switches OFF
S1-1	Manufacturing use ONLY. Leave in OFF position for proper operation.
S1-2	On: USB Host Mode Off: USB Device Mode

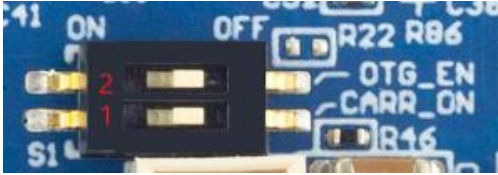

## LED Indicators

### Description

The Hadron/ Hadron DM Carrier implements three LED's (D14, D15, D16) for power status indication as follows:

Function	Description
Location	D14, D15, D16
Type	Green LED
Carrier Connector	Part Number: APHHS1005CGCK Manufacturer: Kingbright
Function	LED
+5V	D14
+3.3V	D15
SYS_ON	D16



Note: When an Orin NX module is not installed, SYS\_ON is state is indeterminate.

## TYPICAL INSTALLATION

1. Ensure all external system power supplies are off and disconnected.
2. Install the NVIDIA® Jetson Orin™ NX/ NVIDIA® Jetson Xavier™ NX Module into the DDR4 260 Pin SODIMM Connector (P1).  
Be sure to follow the manufacturer's directions for proper installation of mounting hardware, heatsink / heat-spreader, and any other applicable requirements from the manufacturer.
3. Install the necessary cables based on your application:
  1. Connect Power cable to the input power connector (P8)
  2. Connect a 3.3V TTL FTDI Serial cable to UART2 pins on Pin 37 and Pin 38 of the I/O Header (P4)
  3. If network connectivity is required, plug-in CBG117 at P2
4. Connect the Power Cable of the Power Supply into the Power header (P8)  
Plug the AC cable of the Power Supply into the wall.
5. Access the debug UART port using a standard 3.3V TTL FTDI cable to any computer over USB. Another TTL UART interface is required to use the debug port. The default serial settings are 115200 8N1 (standard settings) but hardware flow control must be turned off.

If using minicom in Linux based systems, serial into the system through disabling the hardware flow control:

1. Press CTRL+A
2. Press o
3. Go to Serial Port Setup
4. Press F (To change hardware flow control to off)
5. (optional) save as default in previous menu

If using putty in Windows based systems, in the left menu go to serial>flow control>None.

**DO NOT** power up your system by plugging in live power.



# MECHANICAL DETAILS

Full 3D Model of Hadron/ Hadron DM Carrier and XBG023 can be found here:

[https://connecttech.com/ftp/3d\\_models/NGX012\\_3D\\_MODEL.zip](https://connecttech.com/ftp/3d_models/NGX012_3D_MODEL.zip)

[https://connecttech.com/ftp/3d\\_models/NGX024\\_3D\\_MODEL.zip](https://connecttech.com/ftp/3d_models/NGX024_3D_MODEL.zip)

[https://connecttech.com/ftp/3d\\_models/XBG023B\\_3D\\_Model.zip](https://connecttech.com/ftp/3d_models/XBG023B_3D_Model.zip)

## NGX012 – Hadron - Stand Alone Drawings

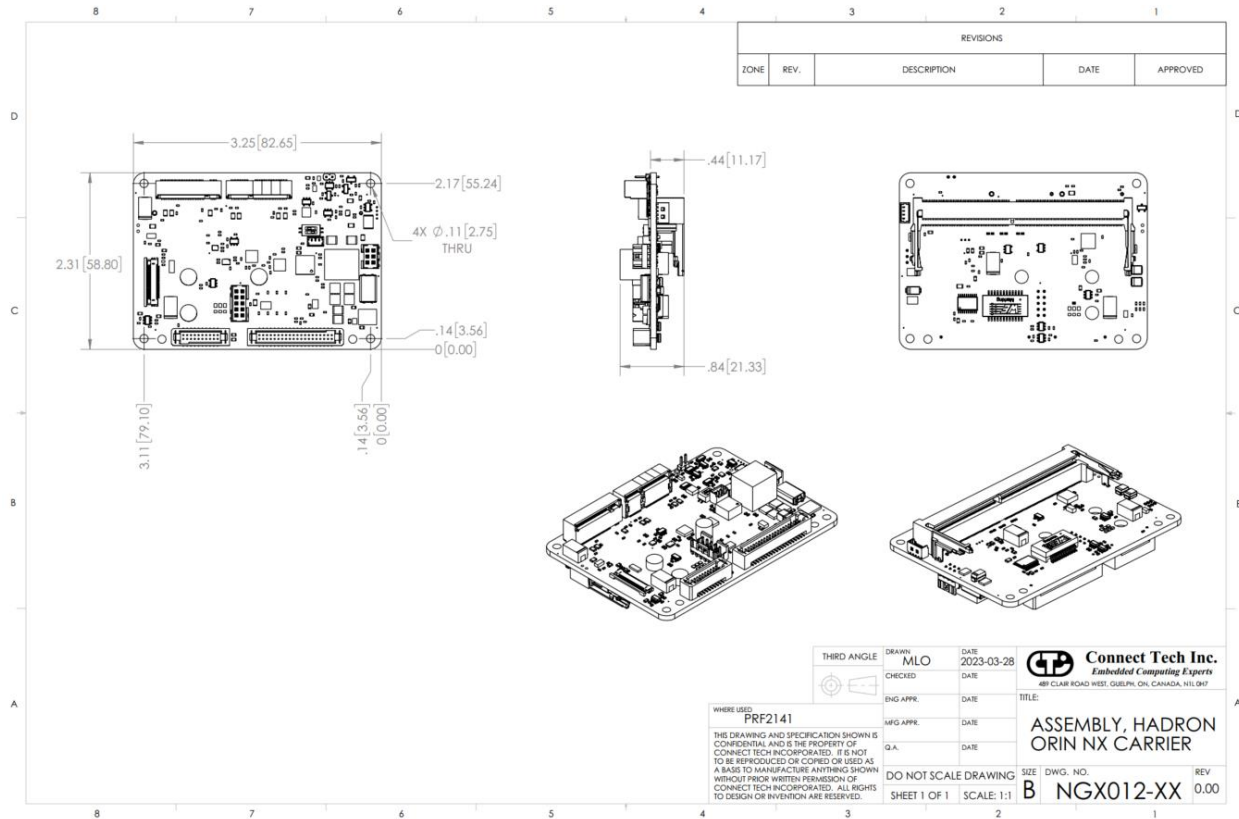

### NGX012-XX – Hadron TTP Integration Details (w/ Wi-Fi + 2242 NVMe)

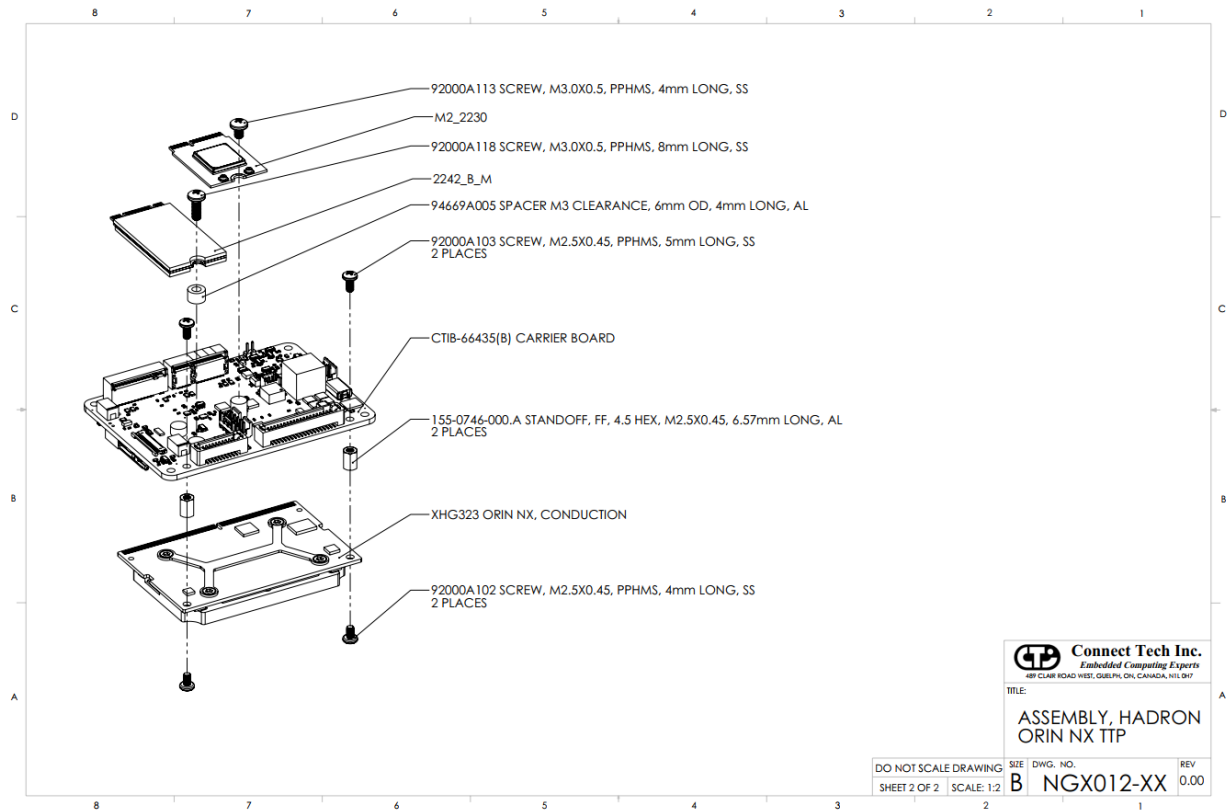
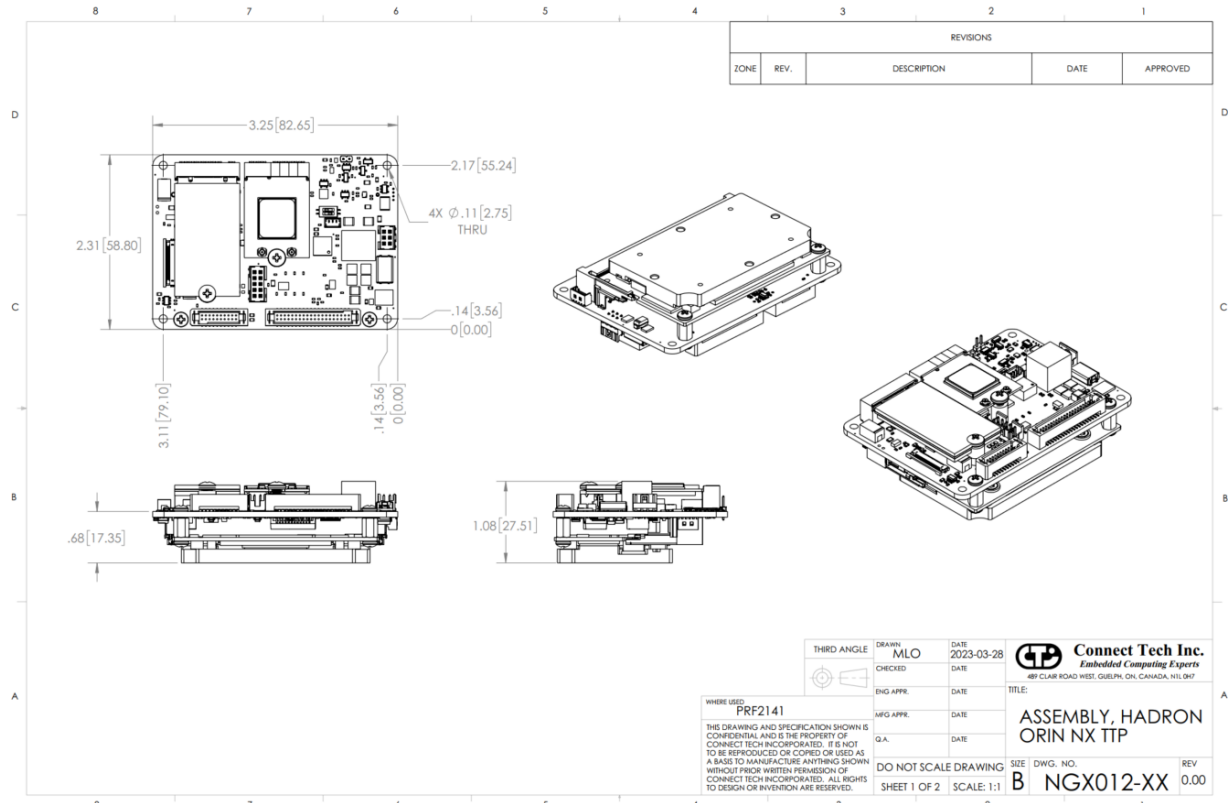

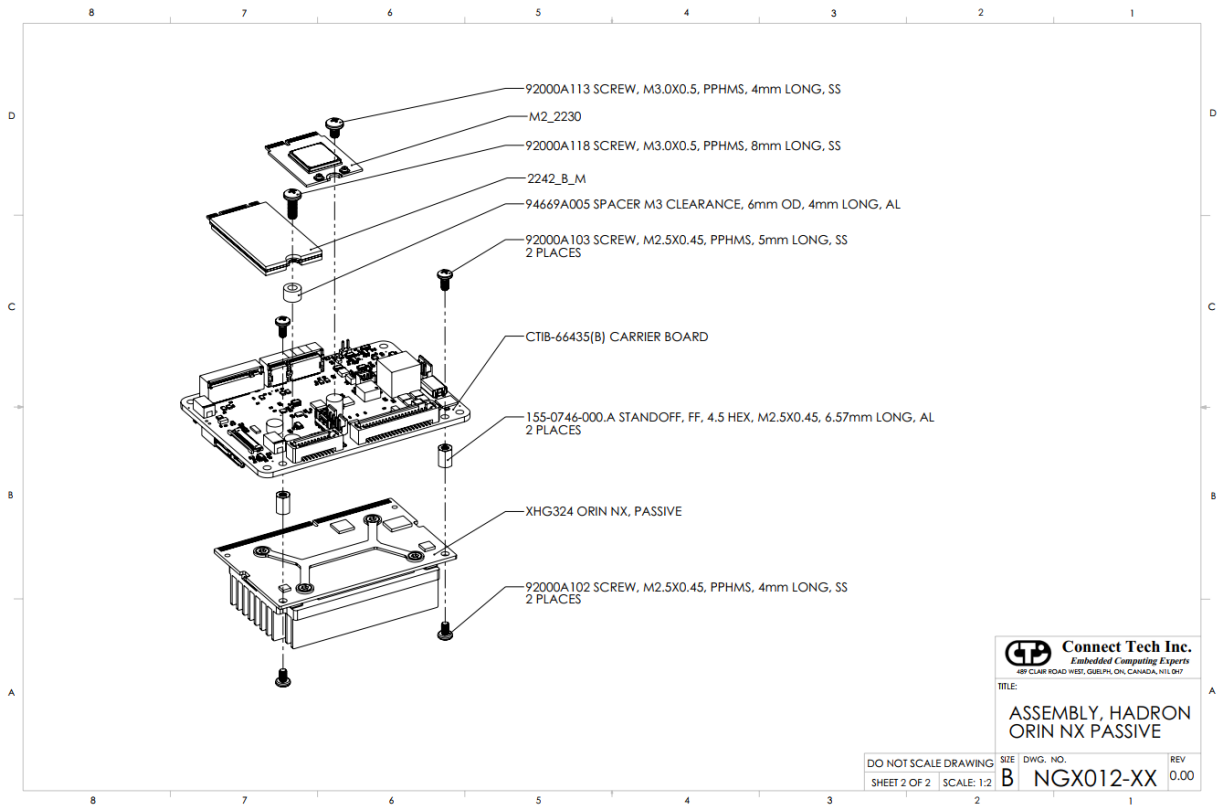
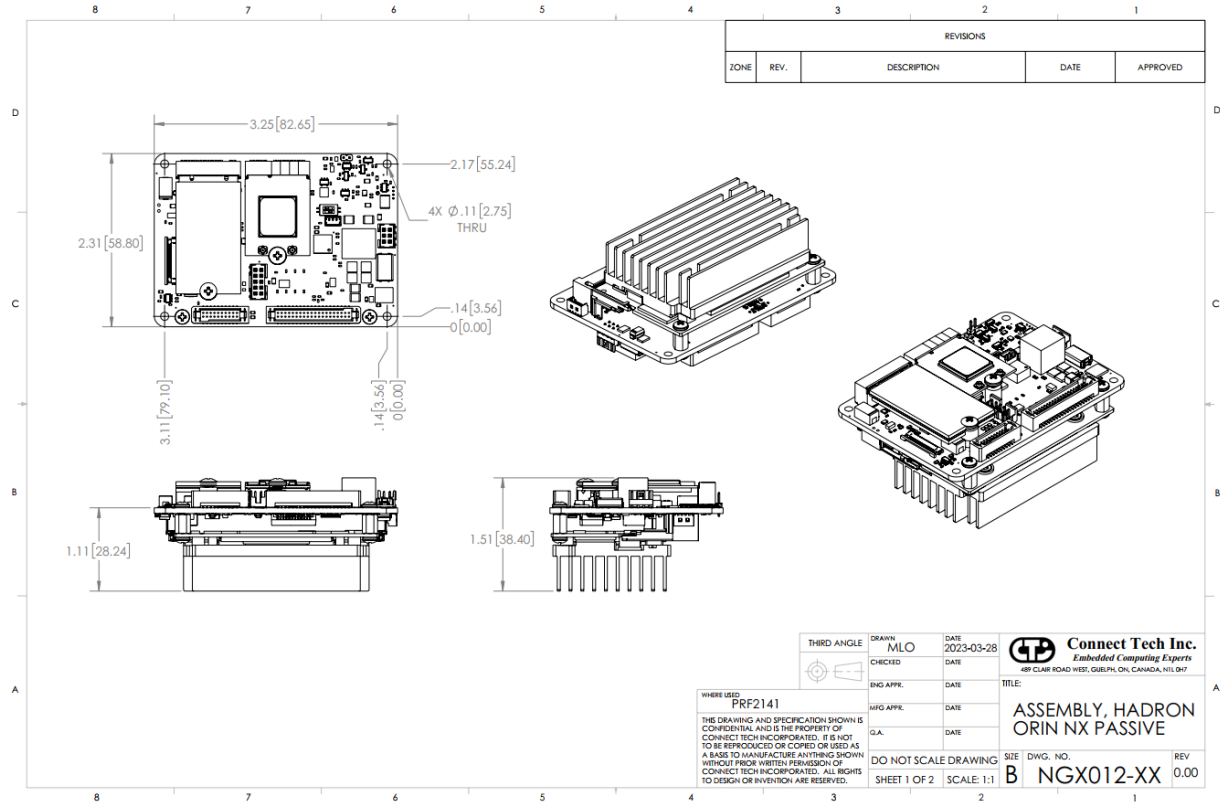
**NGX012-XX – Hadron Passive Thermal Integration Details (w/ Wi-Fi + 2242 NVMe)**

### NGX012-XX – Hadron Active Thermal Integration Details (w/ Wi-Fi + 2242 NVMe)

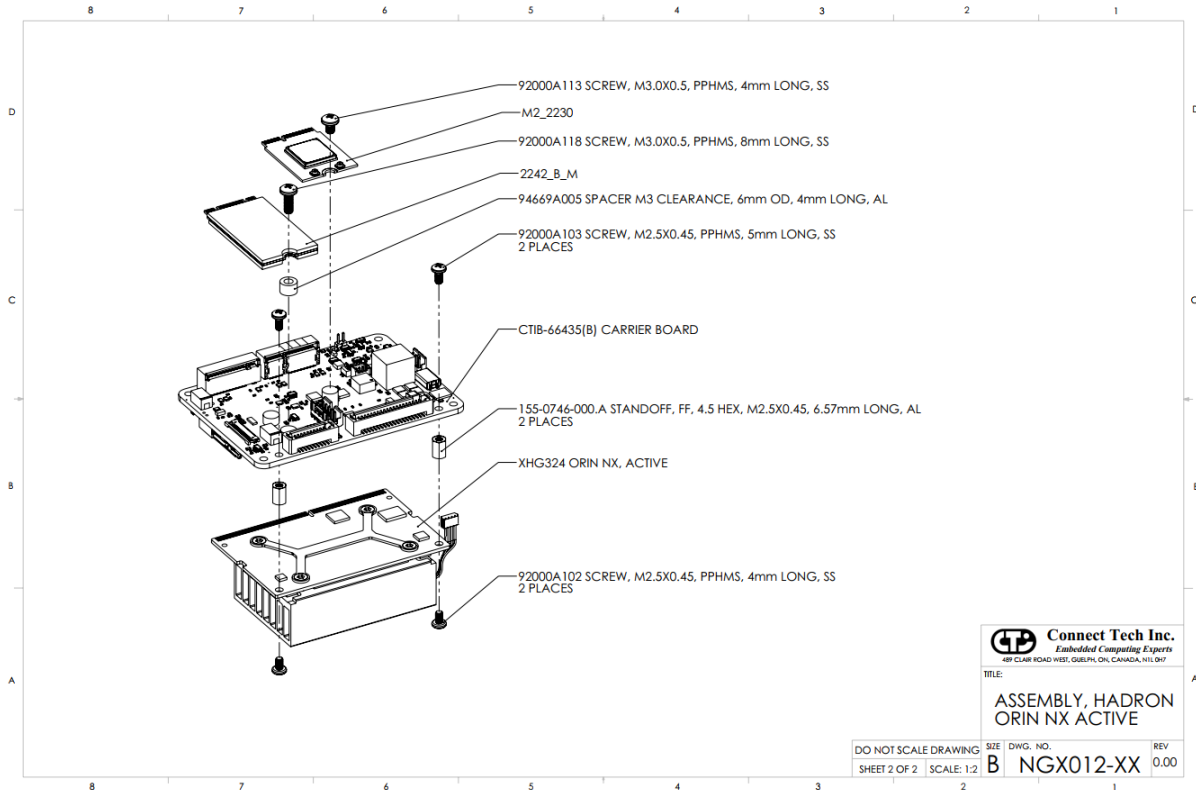
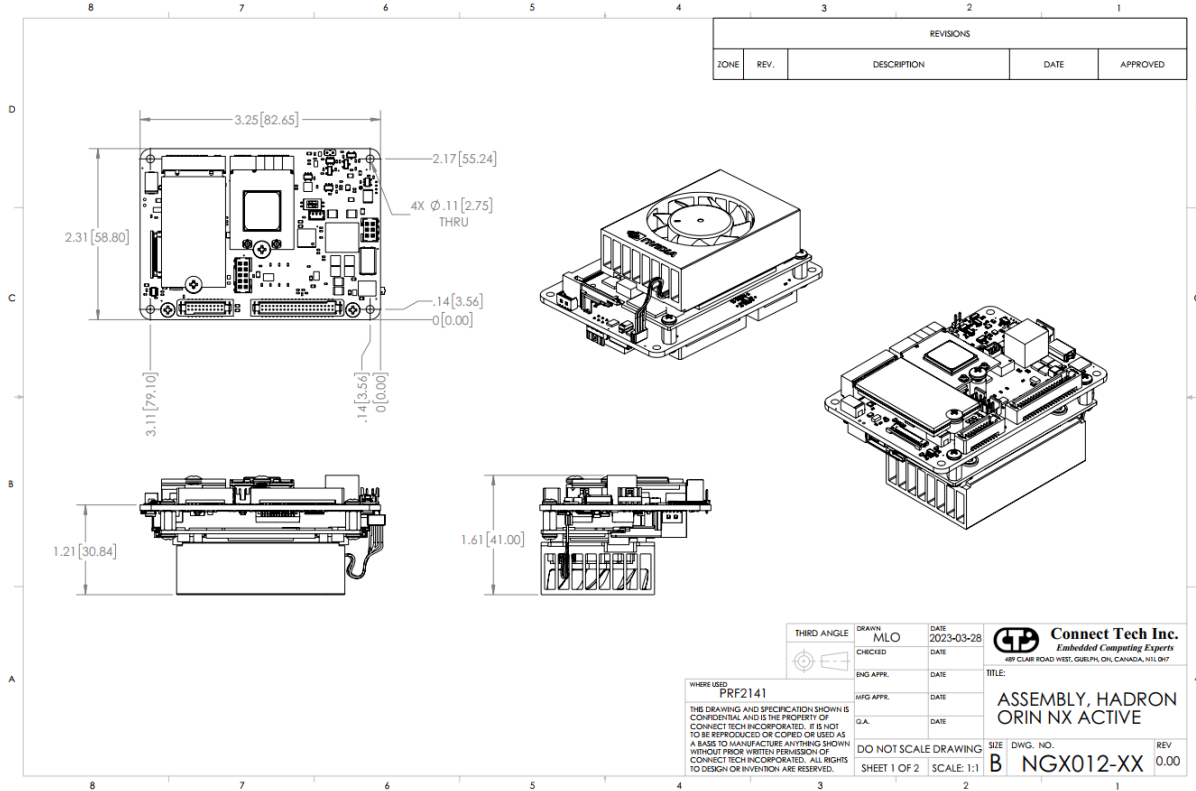

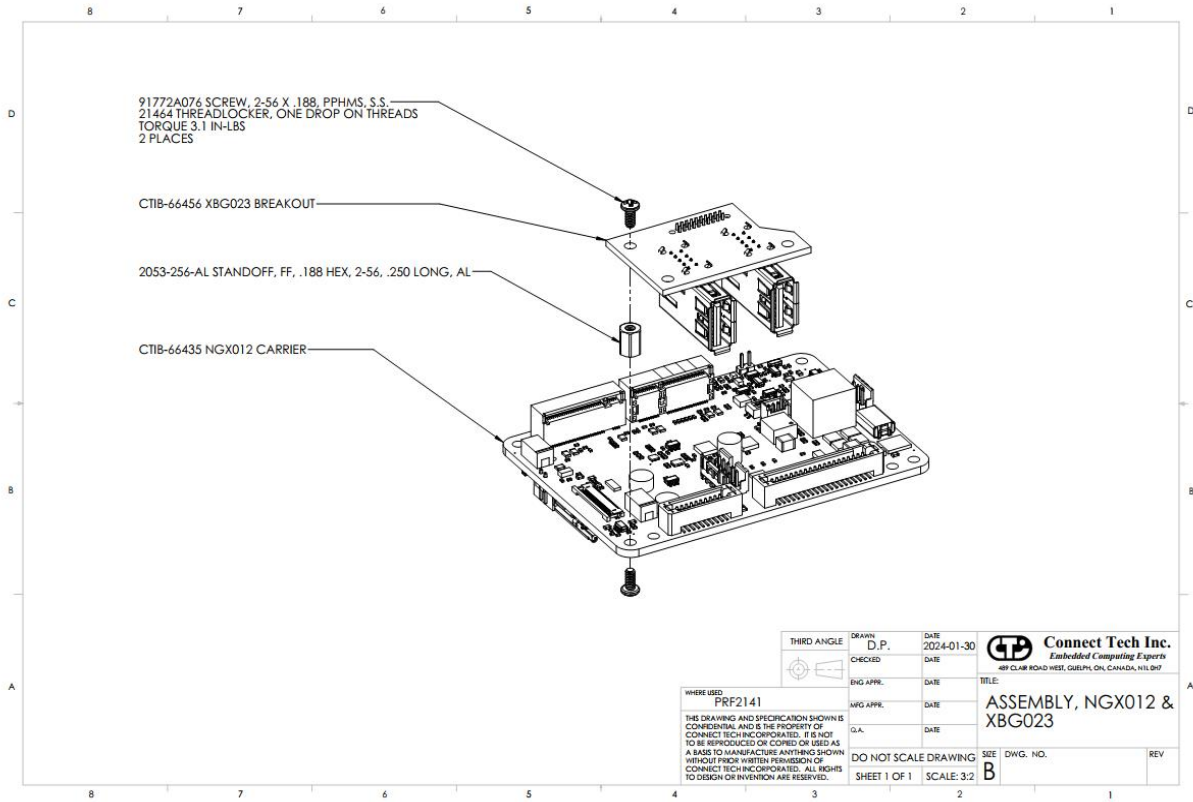
**NGX012/024 and XBG023 Integration Drawing**

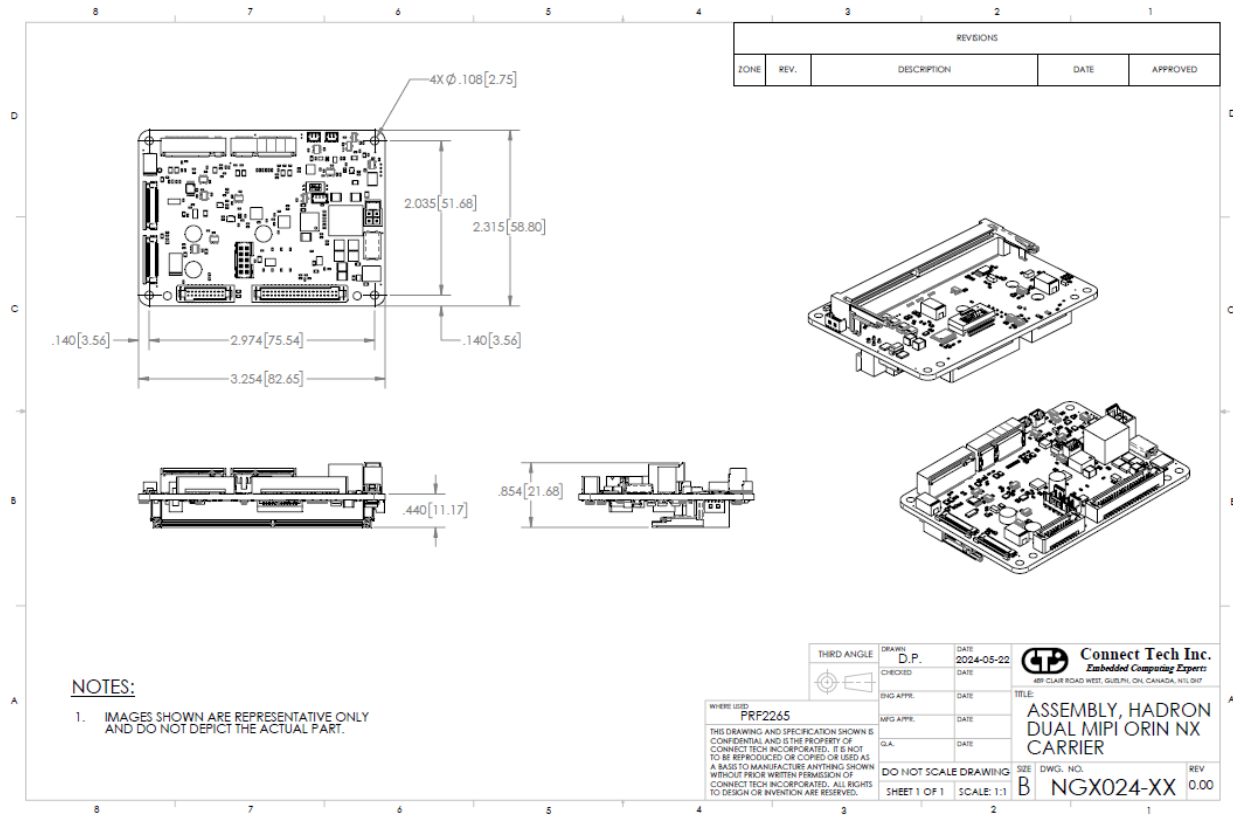
**NGX024 – Hadron DM Carrier - Stand Alone Drawings**

NGX024-XX – Hadron DM TTP Integration Details (w/ Wi-Fi + 2242 NVMe)

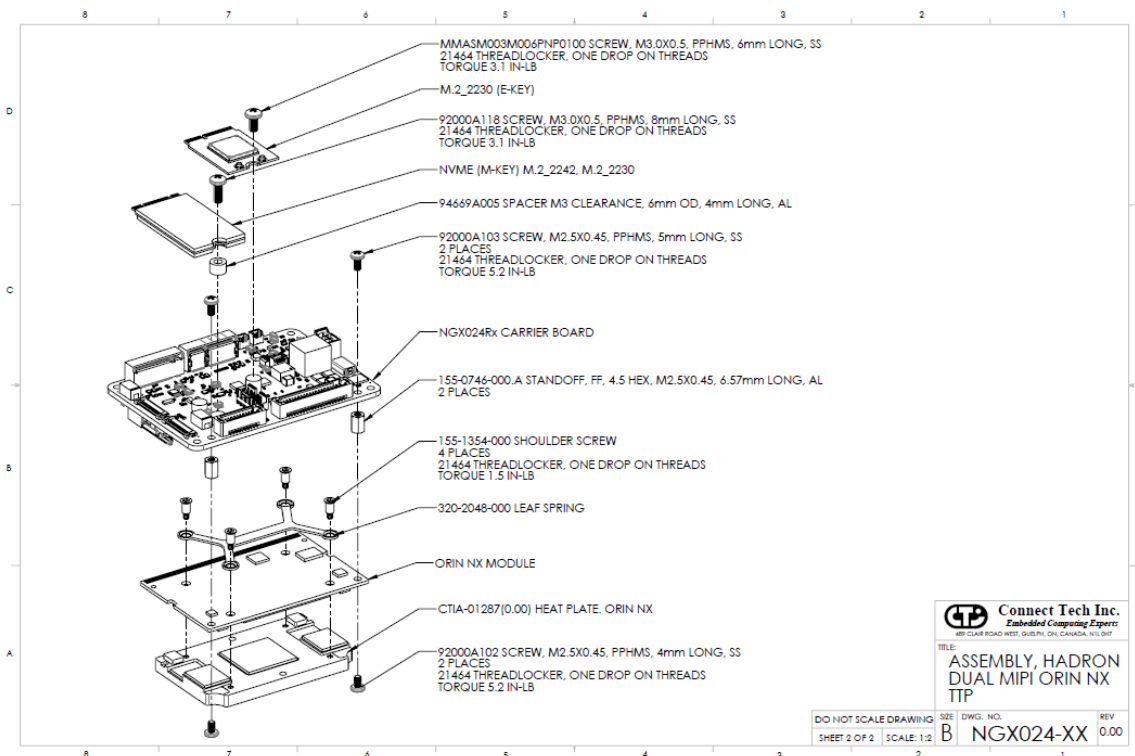
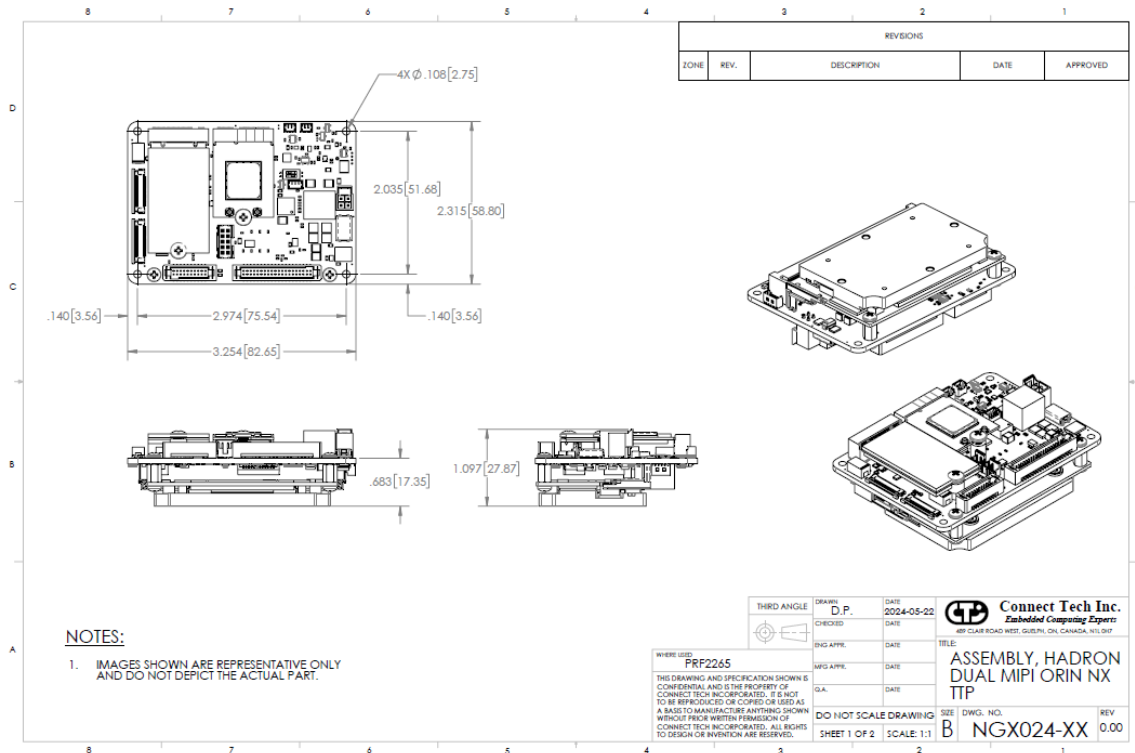

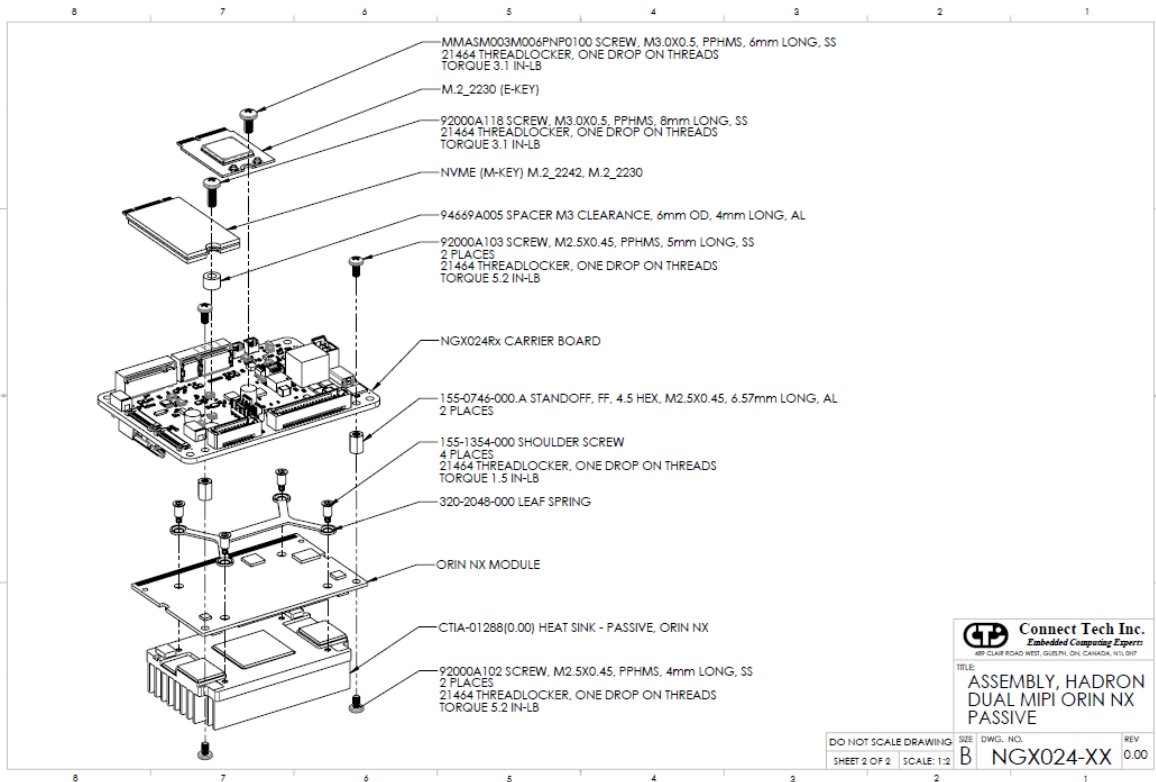
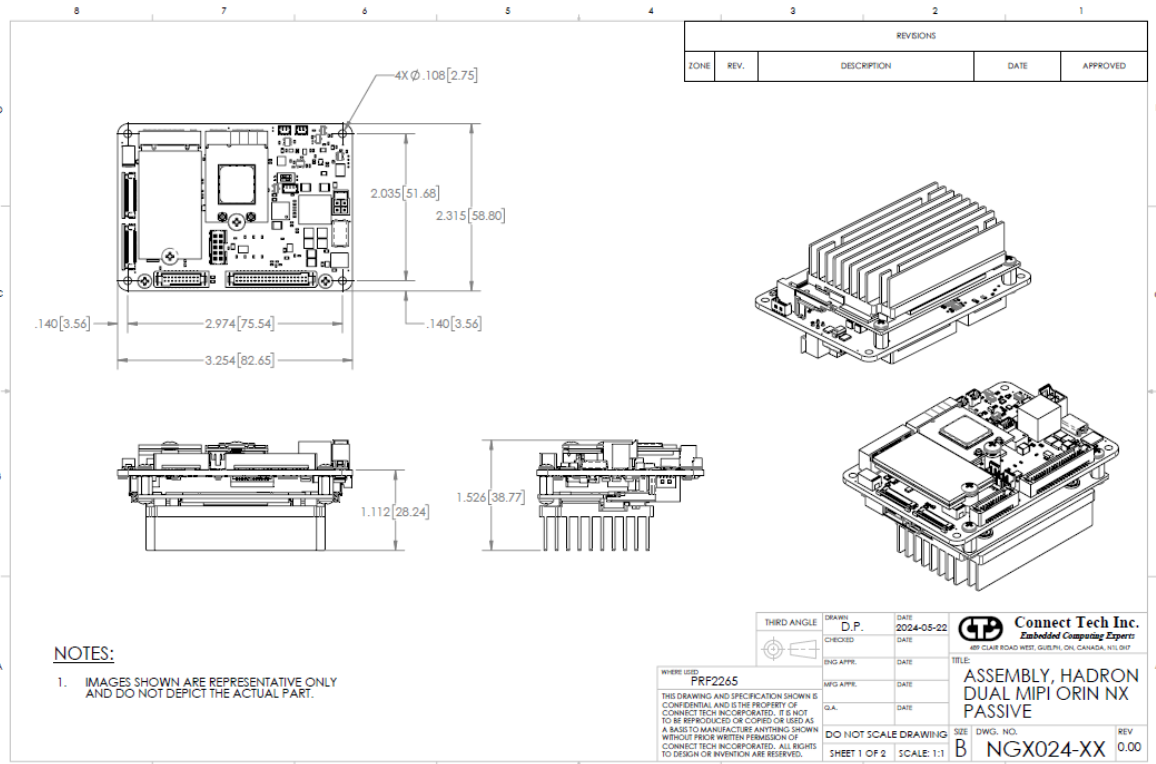
**NGX024-XX – Hadron DM Passive Thermal Integration Details (w/ Wi-Fi + 2242 NVMe)**

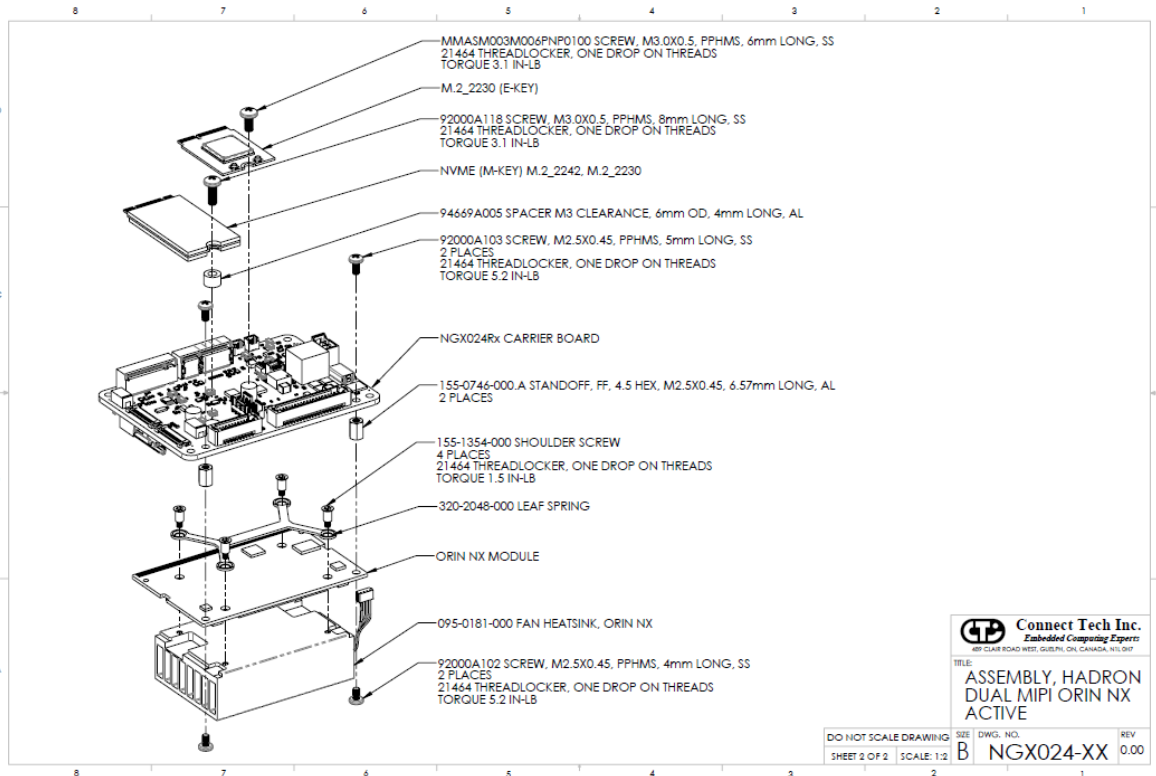
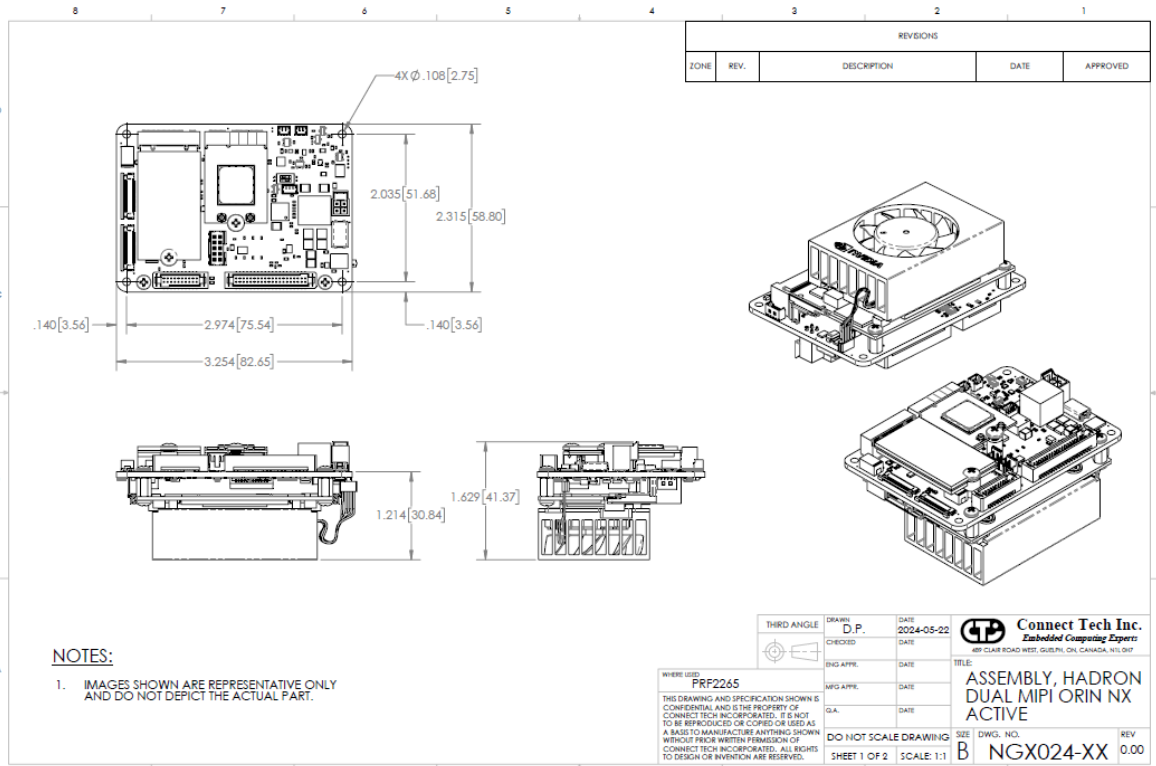

**NGX024-XX – Hadron DM Active Thermal Integration Details (w/ Wi-Fi + 2242 NVMe)**

## THERMAL DETAILS

The Hadron/Hadron DM Carrier has an Operating Temperature Range of -25°C to +85°C.

However, it is important to note that the NVIDIA® Jetson Orin™ NX/ NVIDIA® Jetson Xavier™ NX Module has its own properties separate to that of the Hadron/Hadron DM Carrier. The Hadron and Hadron DM are rated for Operating Temperature Range of -25°C to +85°C.

Customer responsibility requires proper implementation of a thermal solution that maintains the Hadron SoC and Thermal Transfer Plate (TTP) temperatures below the specified temperatures (shown in the tables below) under the maximum thermal load and system conditions for their use case.

### NVIDIA® Jetson Orin™ NX

Parameter	Value	Units
Maximum Orin™ NX SoC Operating Temperature	T.cpu = 99	°C
	T.gpu = 99	°C
Orin™ NX SoC Shutdown Temperature	T.cpu = 105	°C
	T.gpu = 105	°C

### NVIDIA® Jetson Xavier™ NX

Parameter	Value	Units
Maximum Xavier™ SoC Operating Temperature	T.cpu = 90.5	°C
	T.gpu = 91.5	°C
Xavier™ SoC Shutdown Temperature	T.cpu = 96.0	°C
	T.gpu = 95.5	°C

## CABLE INFORMATION

Drawing No.	Part No.	Function	Description
<a href="#">CTIC-00431</a>	CBG112 (NGX012 Only)	Power Cable	6-pin MiniTek w/ Latch, unterminated
<a href="#">CTIC-00883</a>	CBG732 (NGX024 only)	Power Cable	Nano-Fit 2x2 to DC Jack Power Cable
<a href="#">CTIC-00433</a>	CBG117	Ethernet Cable	10-pin MiniTek w/ Latch, RJ-45 Panel Mount
<a href="#">CTIC-00477</a>	CBG136	RTC Battery Cable	Molex 3 Position 1.25mm PicoBlade Connector
N/A	CBG615	USB2.0 Cable	20-pin Tiger-Eye to 2x USB 2.0 Type-A Female

N/A	CBG629	I/O cable	40-pin Tiger-Eye to Unterminated Flying Leads
N/A	CBG686	USB3.0 Cable	20-pin Tiger-Eye to 2x USB 3.0 Type-A Female (200mm)
N/A	XBG023	USB 3.0 Breakout Board	20-pin Tiger-Eye to 2x USB 3.0 Type-A Female

### Cable Components:

Below is the list of components required to assemble the USB and I/O cable for Hadron/Hadron DM Carrier:

Component	USB Cable	I/O Cable
Connector Housing	ISDF-10-D-M	ISDF-20-D-M
Crimp Contact	CC03M-2830-GF	CC03M-2830-GF
Crimp Hand tool	CAT-HT-203-2830-12	CAT-HT-203-2830-12
Wire Gauge	28 – 30 AWG	28 – 30 AWG
Notes	USB Differential pairs needs to be twisted pairs	3.3V and 5V output is limited to 500mA each.

## CONNECT TECH CUSTOM THERMAL SOLUTIONS

Connect Tech Inc. has three custom solutions available for customer implementation, namely, an Active Cooling Solution, a Passive Cooling Solution, and a Thermal Transfer Plate Solution. Please note the different part numbers for NVIDIA® Jetson Orin™ NX / Orin Nano and NVIDIA® Jetson Xavier™ NX thermal solutions.

### Connect Tech Inc. NVIDIA® Jetson Orin™ NX / Orin Nano Thermal Solutions

Function	Part Number
Orin NX / Orin Nano - Active Heatsink	XHG325
Orin NX / Orin Nano - Passive Heatsink	XHG324
Orin NX / Orin Nano - Thermal Transfer Plate	XHG323
Xavier NX - Active Heatsink	XHG312
Xavier NX - Passive Heatsink	XHG311
Xavier NX - Thermal Transfer Plate	XHG313

## CURRENT CONSUMPTION DETAILS

### NVIDIA® Jetson Orin™ NX

Parameter	Value	Units	Temperature
NVIDIA® Jetson Orin™ NX Module, Passive Cooling, Idle, Ethernet, Mouse and Keyboard plugged in	7.5	W	25°C (typ.)
NVIDIA® Jetson Orin™ NX Module 8GB, Active Cooling, MAXN mode (5 cores full load, 1 core for CPU stress utility), CPU-stressed, GPU-stressed, Ethernet, Mouse and Keyboard plugged in	29.1	W	25°C (typ.)
NVIDIA® Jetson Orin™ NX Module 16GB, Active Cooling, MAXN mode (7 cores full load, 1 core for CPU stress utility), CPU-stressed, GPU-stressed, Ethernet, Mouse and Keyboard plugged in	32.3	W	25°C (typ.)

### NVIDIA® Jetson Xavier™ NX

Parameter	Value	Units	Temperature
NVIDIA® Jetson Xavier™ NX Module, Passive Cooling, Idle, Ethernet, Mouse and Keyboard plugged in	10	W	25°C (typ.)
NVIDIA® Jetson Xavier™ NX Module, Active Cooling, 20W - 6 core mode, CPU-stressed, GPU-stressed, Ethernet, Mouse and Keyboard plugged in	27	W	25°C (typ.)

## SOFTWARE / BSP DETAILS

All Connect Tech NVIDIA® Jetson-based products are built upon a modified Linux for Tegra (L4T) Device Tree that is specific to each CTI product.

**WARNING:** The hardware configurations of CTI's products differ from those of the NVIDIA® supplied evaluation kit. Please review the product documentation and install ONLY the appropriate CTI L4T BSPs. Failure to follow this process could result in non-functional hardware.

# ANNEXURE I

## NGX012 vs NGX024

### Specification Differences

Feature	Details	
	NGX012	NGX024
<b>Jetson Module Compatibility</b>	NVIDIA® Jetson Xavier™ NX NVIDIA® Jetson Orin™ NX	NVIDIA® Jetson Xavier™ NX NVIDIA® Jetson Orin™ NX
<b>Ethernet</b>	1x 1000BASE-T Ethernet Port - 1x sourced from Native Jetson Port - Connector: Amphenol Minitex 10 pin (PN: 98411-G06-10LF) - Compatible Cable: CBG117	1x 1000BASE-T Ethernet Port - 1x sourced from Native Jetson Port - Connector: Amphenol Minitex 10 pin (PN: 98411-G06-10LF) - Compatible Cable: CBG117
<b>USB</b>	2x USB 3.0 (one with OTG capability, the other without) - Connector: TFM 20-pin	2x USB 3.0 (one with OTG capability, the other without) - Connector: TFM 20-pin
<b>Storage</b>	1x M.2 M-Key 2230/2242 SSD Slot (PCIe x4)	1x M.2 M-Key 2230/2242 SSD Slot (PCIe x4)
<b>Wireless Expansion</b>	1x M.2 E-Key (2230 Sized) - PCIe + USB 2.0 Sourced from NX	1x M.2 E-Key (2230 Sized) - PCIe + USB 2.0 Sourced from NX
<b>UART</b>	1x 3.3V Logic Level UART (Debug Port) - RX/TX/GND Only 2x RS232 Line Level - TX, RX, RTS, CTS, GND All three go to connector: Grouped IO TFM 40-pin	1x 3.3V Logic Level UART (Debug Port) - RX/TX/GND Only 2x RS232 Line Level - TX, RX, RTS, CTS, GND All three go to connector: Grouped IO TFM 40-pin
<b>I2C</b>	1x 3.3V I2C Host Ports - Connector: Grouped IO TFM 40-pin	1x 3.3V I2C Host Ports Connector: Grouped IO TFM 40-pin
<b>SPI</b>	1x 3.3V SPI Host Ports - Connector: Grouped IO TFM 40-pin	1x 3.3V SPI Host Ports - Connector: Grouped IO TFM 40-pin
<b>GPIO</b>	4x 3.3V Logic GPIO Pins - Sourced from module - 1x GPIO will function as Output only (GTRI power enable block) - Connector: Grouped IO TFM 40-pin	4x 3.3V Logic GPIO Pins - Sourced from module - 1x GPIO will function as Output only (GTRI power enable block) - Connector: Grouped IO TFM 40-pin
<b>Display Output</b>	None (headless)	None (headless)
<b>MIPI</b>	<b>1x 4-lane MIPI CSI-2</b>	<b>2x 4-lane MIPI CSI-2</b>
<b>FAN</b>	1x FAN w/ PWM Control (5V operation) - Connector: Picoblade	1x FAN w/ PWM Control (5V operation) Connector: Picoblade
<b>Input Power / Misc Power Details</b>	Single Input +9V to +60V (Nominal will be +15.8V) - Connector: 6-pin Minitex Connector - Cable: CBG112 - Auto-ON operation by default	Single Input +9V to +60V (Nominal will be +15.8V) - Connector: 4-pin Molex Nano-Fit connector - Cable: CBG706 - Auto-ON operation by default - Power/Wake switch
<b>Battery</b>	3V RTC battery - Connector: Picoblade 3-pin	3V RTC battery - Connector: Picoblade 3-pin
<b>Operating Temperature</b>	-25°C to +85°C (Carrier board operating temp only)	-25°C to +85°C (Carrier board operating temp only)
<b>PCB Thickness</b>	2mm	2mm
<b>PCBA Inspection and Acceptance Criteria</b>	IPC-A-610 Class 2	IPC-A-610 Class 2
<b>Mechanical Details</b>	82.65mm x 58.80mm	82.65mm x 58.80mm
<b>Environmental Requirements</b>	Ingress Protection: N/A EMC/EMI: N/A Shock/Vibration: N/A <b>Test Not Required by Connect Tech</b>	Ingress Protection: N/A EMC/EMI: N/A Shock/Vibration: N/A <b>Test Not Required by Connect Tech</b>
<b>Warranty and Support</b>	1 Year Warranty and Free Support	1 Year Warranty and Free Support

## MIPI

NGX012 can support one CSI-2 connector, while NGX024 has the added capability to support an additional CSI-2 connector.

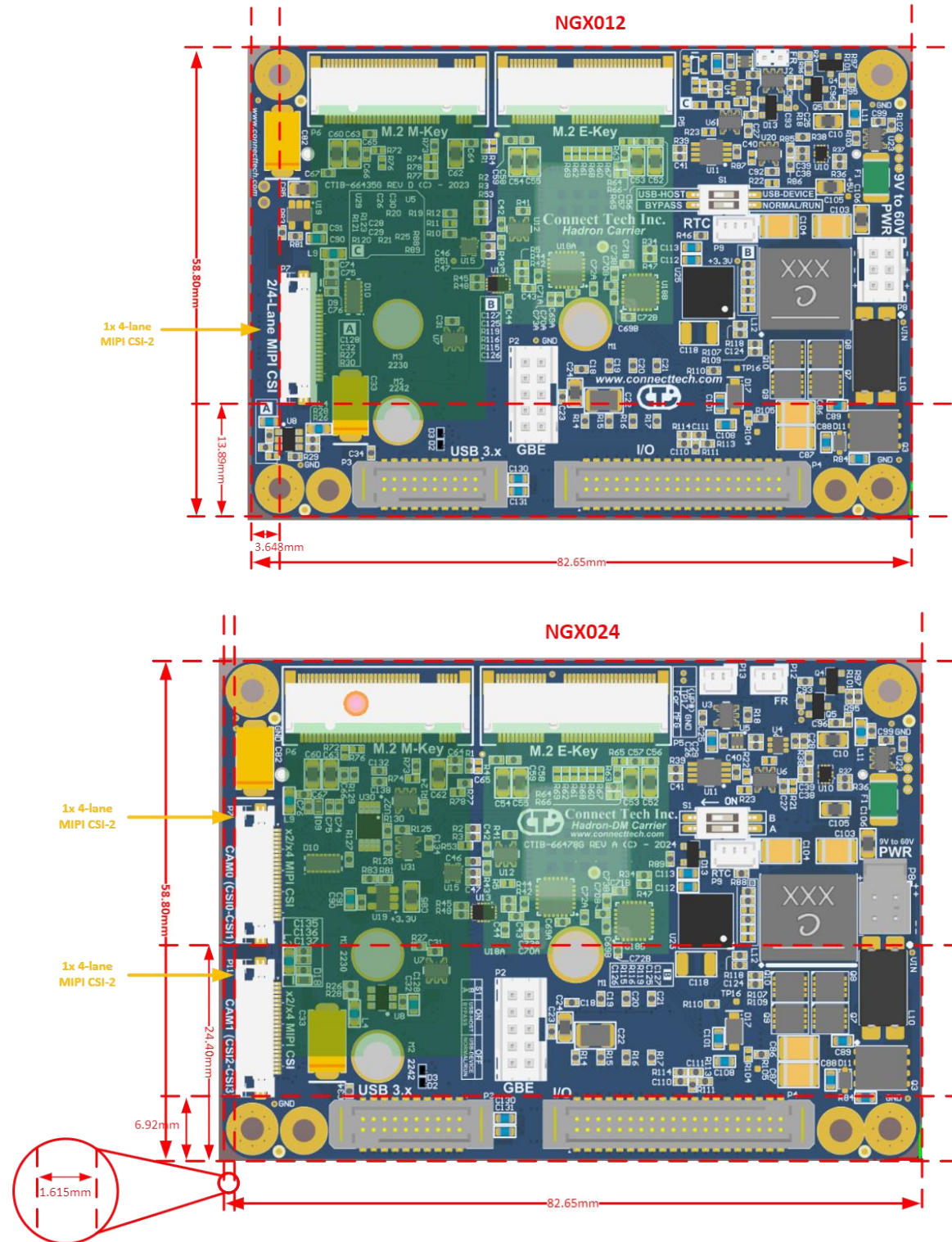

## Input Power connector

The power connector for NGX024 has been upgraded to support the additional power required for the new camera. The height of the connector has also been changed as shown in the diagram below.

Power connector:

NGX024: 2x2 Molex Nano-Fit

NGX012: 2x3 TH 2mm MiniTek

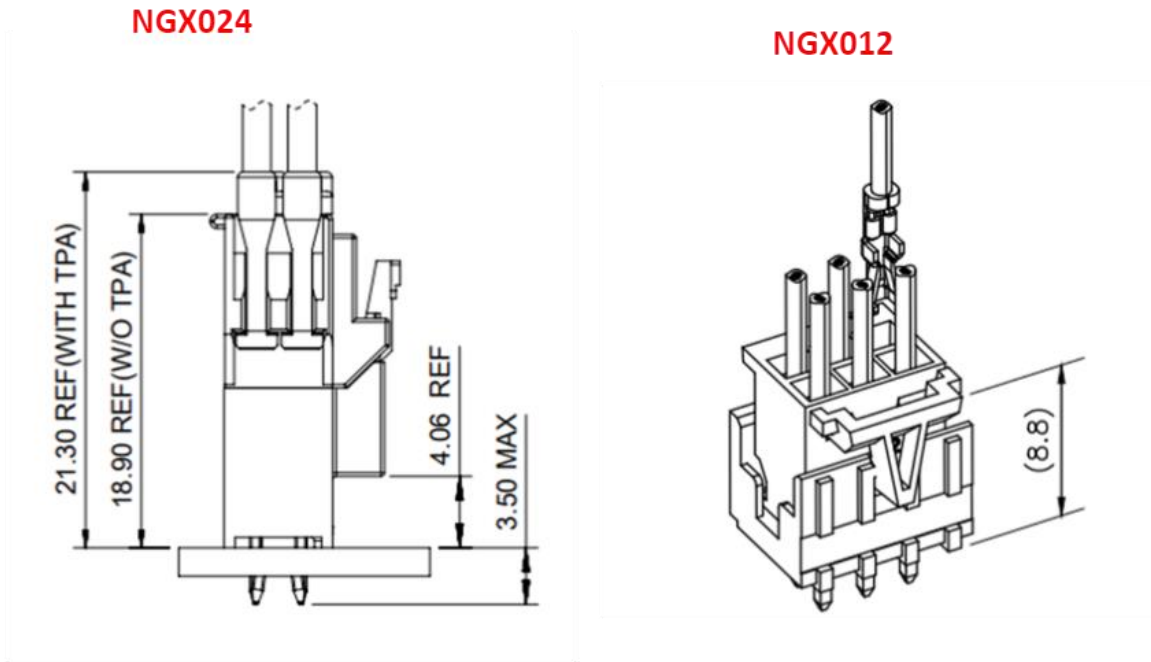

## Force Reset Connector

The force reset connector has been upgraded from 1x2 2mm jumper to a 1x2 miniTek latch connector.

Function	Description	
Location	P12	
Type	1x2 TH 1.25mm (Molex – PicoBlade) connector	
	Pin	Description
	1	FR/RST
	2	GND

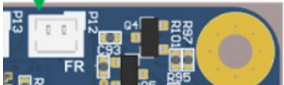

Force Reset Switch  
(1x2 TH 1.25mm Molex-PicoBlade latch connector)



**Additional Feature:**

One Power/Wake connector has been added to wake the device from sleep or shutdown mode.

Function	Description	
Location	P13	
Type	1x2 TH 1.25mm (Molex – PicoBlade) connector	
	Pin	Description
	1	SYS.SLEEP/WAKE #
	2	GND

